



Maxim > Products > [Supervisors, Voltage Monitors, Sequencers]

DS1232LP

Low-Power MicroMonitor Chip

Description

The DS1232LP/LPS Low-Power MicroMonitor Chip monitors three vital conditions for a microprocessor: power supply, software execution, and external override. First, a precision temperature-compensated reference and comparator circuit monitors the status of V_{CC} . When an out-of-tolerance condition occurs, an internal power-fail signal is generated, which forces reset to the active state. When V_{CC} returns to an in-tolerance condition, the reset signals are kept in the active state for a minimum of 250ms to allow the power supply and processor to stabilize.

Key Features

- Super-low power version of DS1232
- 50 μ A quiescent current
- Halts and restarts an out-of-control microprocessor
- Automatically restarts microprocessor after power failure
- Monitors pushbutton for external override
- Accurate 5% or 10% microprocessor power supply monitoring
- 8-pin DIP, 8-pin SO, or space saving μ SOP package available
- Optional 16-pin SO package available
- Industrial temperature -40°C to +85°C available, designated N

Key Specifications: Supervisors (1 Monitored Voltage)

Part Number	Reset Threshold Range (V)	Active-Low Reset Output	Active-High Reset Output	Min. Reset Timeout Range	Watchdog Feature	Nom. Watchdog Timeout Range	Supervisor Features	Reset Thresh. Acc. (% @+25°C)	Max. I_{CC} (μ A)	
DS1232LP	3.3 to 5.5	Open Drain	Push-Pull	85ms to 300ms	Input (WDI)	1s to 2s <1s	Manual Reset	2.5	50	

Notes:

**This pricing is BUDGETARY, for comparing similar parts. Prices are in U.S. dollars and subject to change. Quantity pricing may vary substantially and international prices may differ due to local duties, taxes, fees, and exchange rates. For volume-specific prices and delivery, please see the [price and availability page](#) or contact an authorized distributor.

Application Notes

[Application Note 3316: Dallas Semiconductor Microprocessor Supervisor Selection Guide - DS1232LP](#)

Evaluation Kits

none

Design Guides

[Microprocessor Supervisory \(PDF\)](#)

Reliability Reports

Request Reliability Report for:

Software/Models

none

Ordering Information

Notes:

1. Other options and links for purchasing parts are listed at:
2. [Didn't Find What You Need?](#) Ask our applications engineers. Expert assistance in finding parts, usually within one business day.
3. Part number suffixes: T or T&R = tape and reel; + = RoHS/lead-free; # = RoHS/lead-exempt. More: [See Full Data Sheet](#) or [Part Naming Conventions](#).
4. * Some packages have variations, listed on the drawing. "PkgCode/Variation" tells which variation the product uses. Note that "+", "#", "-" in the part number suffix describes RoHS status. Package drawings may show a different suffix character.

DS1232LP	Notes	Free Sample	Buy	Package: TYPE PINS FOOTPRINT DRAWING CODE/VAR *	Temp	RoHS/Lead-Free? Materials Analysis
DS1232LP				PDIP; 8 pin; Dwg: 21-0043 (PDF) Use pkgcode/variation: P8-1*	0°C to +70°C	RoHS/Lead-Free: No Materials Analysis
DS1232LP+				PDIP; 8 pin; Dwg: 21-0043 (PDF) Use pkgcode/variation: P8+1*	0°C to +70°C	RoHS/Lead-Free: Lead Free Materials Analysis
DS1232LPN				PDIP; 8 pin; Dwg: 21-0043 (PDF) Use pkgcode/variation: P8-1*	-40°C to +85°C	RoHS/Lead-Free: No Materials Analysis
DS1232LPN+				PDIP; 8 pin; Dwg: 21-0043 (PDF) Use pkgcode/variation: P8+1*	-40°C to +85°C	RoHS/Lead-Free: Lead Free Materials Analysis
DS1232LPS-2/TR+C01				SOIC; 8 pin; Dwg: 21-0041 (PDF) Use pkgcode/variation: S8+2*	0°C to +70°C	RoHS/Lead-Free: Lead Free Materials Analysis
DS1232LPS-2/T&R/C01					0°C to +70°C	See data sheet
DS1232LPSN+T&R				SOIC; 16 pin; Dwg: 21-0042 (PDF) Use pkgcode/variation: W16+11*	-40°C to +85°C	RoHS/Lead-Free: Lead Free Materials Analysis
DS1232LPS+T&R	T&R Qty 1000/Reel			SOIC; 16 pin; Dwg: 21-0042 (PDF) Use pkgcode/variation: W16+11*	0°C to +70°C	RoHS/Lead-Free: Lead Free Materials Analysis
DS1232LPS+				SOIC; 16 pin; Dwg: 21-0042 (PDF) Use pkgcode/variation: W16+11*	0°C to +70°C	RoHS/Lead-Free: Lead Free Materials Analysis
DS1232LPS/T&R	T&R Qty 1000/Reel			SOIC; 16 pin; Dwg: 21-0042 (PDF) Use pkgcode/variation: W16-11*	0°C to +70°C	RoHS/Lead-Free: No Materials Analysis
DS1232LPS				SOIC; 16 pin; Dwg: 21-0042 (PDF) Use pkgcode/variation: W16-11*	0°C to +70°C	RoHS/Lead-Free: No Materials Analysis
DS1232LPSN/T&R	T&R Qty 1000/Reel			SOIC; 16 pin; Dwg: 21-0042 (PDF) Use pkgcode/variation: W16-11*	-40°C to +85°C	RoHS/Lead-Free: No Materials Analysis

DS1232LPSN+			SOIC; 16 pin; Dwg: 21-0042 (PDF) Use pkgcode/variation: W16+11*	-40°C to +85°C	RoHS/Lead-Free: Lead Free Materials Analysis
DS1232LPSN			SOIC; 16 pin; Dwg: 21-0042 (PDF) Use pkgcode/variation: W16-11*	-40°C to +85°C	RoHS/Lead-Free: No Materials Analysis
DS1232LPS-2+	Lead-Free		SOIC; 8 pin; Dwg: 21-0041 (PDF) Use pkgcode/variation: S8+2*	0°C to +70°C	RoHS/Lead-Free: Lead Free Materials Analysis
DS1232LPS-2+T&R	T&R Qty 2500/Reel		SOIC; 8 pin; Dwg: 21-0041 (PDF) Use pkgcode/variation: S8+2*	0°C to +70°C	RoHS/Lead-Free: Lead Free Materials Analysis
DS1232LPS-2			SOIC; 8 pin; Dwg: 21-0041 (PDF) Use pkgcode/variation: S8-2*	0°C to +70°C	RoHS/Lead-Free: No Materials Analysis
DS1232LPS-2/T&R	T&R Qty 2500/Reel		SOIC; 8 pin; Dwg: 21-0041 (PDF) Use pkgcode/variation: S8-2*	0°C to +70°C	RoHS/Lead-Free: No Materials Analysis
DS1232LPSN-2+T&R	T&R Qty 2500/Reel		SOIC; 8 pin; Dwg: 21-0041 (PDF) Use pkgcode/variation: S8+2*	-40°C to +85°C	RoHS/Lead-Free: Lead Free Materials Analysis
DS1232LPSN-2+			SOIC; 8 pin; Dwg: 21-0041 (PDF) Use pkgcode/variation: S8+2*	-40°C to +85°C	RoHS/Lead-Free: Lead Free Materials Analysis
DS1232LPSN-2			SOIC; 8 pin; Dwg: 21-0041 (PDF) Use pkgcode/variation: S8-2*	-40°C to +85°C	RoHS/Lead-Free: No Materials Analysis
DS1232LPSN-2/T&R	T&R Qty 2500/Reel		SOIC; 8 pin; Dwg: 21-0041 (PDF) Use pkgcode/variation: S8-2*	-40°C to +85°C	RoHS/Lead-Free: No Materials Analysis
DS1232LPU+			uMAX; 8 pin; Dwg: 21-0036 (PDF) Use pkgcode/variation: U8+1*	0°C to +70°C	RoHS/Lead-Free: Lead Free Materials Analysis
DS1232LPU			uMAX; 8 pin; Dwg: 21-0036 (PDF) Use pkgcode/variation: U8-1*	0°C to +70°C	RoHS/Lead-Free: No Materials Analysis
DS1232LPU/T&R	T&R Qty 3000/Reel		uMAX; 8 pin; Dwg: 21-0036 (PDF) Use pkgcode/variation: U8-1*	0°C to +70°C	RoHS/Lead-Free: No Materials Analysis

FEATURES

- Super-low power version of DS1232
- 50 μ A quiescent current
- Halts and restarts an out-of-control microprocessor
- Automatically restarts microprocessor after power failure
- Monitors pushbutton for external override
- Accurate 5% or 10% microprocessor power supply monitoring
- 8-pin DIP, 8-pin SOIC or space saving μ -SOP package available
- Optional 16-pin SOIC package available
- Industrial temperature -40°C to +85°C available, designated N

PIN ASSIGNMENT

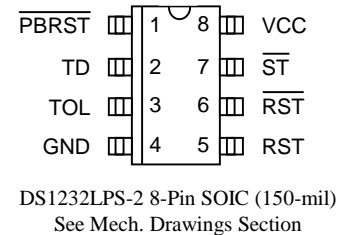
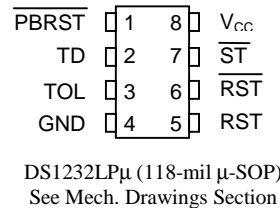
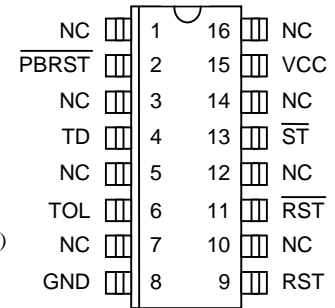
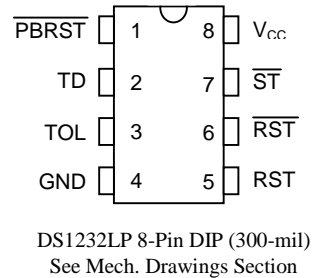

PIN DESCRIPTION

- | | |
|---------------------------|---|
| $\overline{\text{PBRST}}$ | - Pushbutton Reset Input |
| TD | - Time Delay Set |
| TOL | - Selects 5% or 10% V_{CC} Detect |
| GND | - Ground |
| RST | - Reset Output (Active High) |
| $\overline{\text{RST}}$ | - Reset Output (Active Low, open drain) |
| $\overline{\text{ST}}$ | - Strobe Input |
| V_{CC} | - +5 Volt Power |

DESCRIPTION

The DS1232LP/LPS Low Power MicroMonitor Chip monitors three vital conditions for a microprocessor: power supply, software execution, and external over-ride. First, a precision temperature-compensated reference and comparator circuit monitors the status of V_{CC} . When an out-of-tolerance condition occurs, an internal power-fail signal is generated which forces reset to the active state. When V_{CC} returns to an in-tolerance condition, the reset signals are kept in the active state for a minimum of 250 ms to allow the power supply and processor to stabilize.

The second function the DS1232LP/LPS performs is pushbutton reset control. The DS1232LP/LPS debounces the pushbutton input and guarantees an active reset pulse width of 250 ms minimum. The third function is a watchdog timer. The DS1232LP/LPS has an internal timer that forces the reset signals to the active state if the strobe input is not driven low prior to timeout. The watchdog timer function can be set to operate on timeout settings of approximately 150 ms, 600 ms, and 1.2 seconds.

OPERATION - POWER MONITOR

The DS1232LP/LPS detects out-of-tolerance power supply conditions and warns a processor-based system of impending power failure. When V_{CC} falls below a preset level as defined by TOL, the V_{CC} comparator outputs the signals RST and $\overline{\text{RST}}$. When TOL is connected to ground, the RST and $\overline{\text{RST}}$ signals become active as V_{CC} falls below 4.75 volts. When TOL is connected to V_{CC} , the RST and $\overline{\text{RST}}$ signals become active as V_{CC} falls below 4.5 volts. The RST and $\overline{\text{RST}}$ are excellent control signals for a microprocessor, as processing is stopped at the last possible moments of valid V_{CC} . On power-up, RST and $\overline{\text{RST}}$ are kept active for a minimum of 250 ms to allow the power supply and processor to stabilize.

OPERATION - PUSHBUTTON RESET

The DS1232LP/LPS provides an input pin for direct connection to a pushbutton (Figure 1). The pushbutton reset input requires an active low signal. Internally, this input is debounced and timed such that RST and $\overline{\text{RST}}$ signals of at least 250 ms minimum are generated. The 250 ms delay starts as the pushbutton reset input is released from low level.

OPERATION - WATCHDOG TIMER

The watchdog timer function forces RST and $\overline{\text{RST}}$ signals to the active state when the $\overline{\text{ST}}$ input is not stimulated for a predetermined time period. The time period is set by the TD input to be typically 150 ms with TD connected to ground, 600 ms with TD left unconnected, and 1.2 seconds with TD connected to V_{CC} . The watchdog timer starts timing out from the set time period as soon as RST and $\overline{\text{RST}}$ are inactive. If a high-to-low transition occurs on the $\overline{\text{ST}}$ input pin prior to timeout, the watchdog timer is reset and begins to timeout again. If the watchdog timer is allowed to timeout, then the RST and $\overline{\text{RST}}$ signals are driven to the active state for 250 ms minimum. The $\overline{\text{ST}}$ input can be derived from microprocessor address signals, data signals, and/or control signals. When the microprocessor is functioning normally, these signals would, as a matter of routine, cause the watchdog to be reset prior to timeout. To guarantee that the watchdog timer does not timeout, a high-to-low transition must occur at or less than the minimum shown in Table 1. A typical circuit example is shown in Figure 2.

ABSOLUTE MAXIMUM RATINGS*

Voltage on V _{CC} Pin Relative to Ground	-0.5V to +7.0V
Voltage on I/O Relative to Ground	-0.5V to V _{CC} + 0.5V
Operating Temperature	0°C to 70°C
Operating Temperature (Industrial Version)	-40°C to +85°C
Storage Temperature	-55°C to +125°C
Soldering Temperature	260°C for 10 seconds

* This is a stress rating only and functional operation of the device at these or any other conditions above those indicated in the operation sections of this specification is not implied. Exposure to absolute maximum rating conditions for extended periods of time may affect reliability.

RECOMMENDED DC OPERATING CONDITIONS (0°C to 70°C)

PARAMETER	SYMBOL	MIN	TYP	MAX	UNITS	NOTES
Supply Voltage	V _{CC}	4.5	5.0	5.5	V	1
\overline{ST} and \overline{PBRST} Input High Level	V _{IH}	2.0		V _{CC} +0.3	V	1
\overline{ST} and \overline{PBRST} Input Low Level	V _{IL}	-0.3		+0.8	V	1

DC ELECTRICAL CHARACTERISTICS (0°C to 70°C; V_{CC}=4.5 to 5.5V)

PARAMETER	SYMBOL	MIN	TYP	MAX	UNITS	NOTES
Input Leakage	I _{IL}	-1.0		+1.0	μA	3
Output Current @ 2.4V	I _{OH}	-8	-10		mA	5
Output Current @ 0.4V	I _{OL}	10			mA	
Low Level @ RST	V _{OL}			0.4	V	1
Output Voltage @ -500 uA	V _{OH}	V _{CC} -0.5V	V _{CC} -0.1V		V	1, 7
Output Current (CMOS)	I _{CC1}			50	μA	2
Operating Current (TTL)	I _{CC2}		200	500	μA	8
V _{CC} Trip Point (TOL=GND)	V _{CCTP}	4.50	4.62	4.74	V	1
V _{CC} Trip Point (TOL=V _{CC})	V _{CCTP}	4.25	4.37	4.49	V	1

CAPACITANCE (t_A=25°C)

PARAMETER	SYMBOL	MIN	TYP	MAX	UNITS	NOTES
Input Capacitance	C _{IN}			5	pF	
Output Capacitance	C _{OUT}			7	pF	

AC ELECTRICAL CHARACTERISTICS(0°C to 70°C; $V_{CC}=5V \pm 10\%$)

PARAMETER	SYMBOL	MIN	TYP	MAX	UNITS	NOTES
$\overline{PBRST} = V_{IL}$	t_{PB}	20			ms	
RESET Active Time	t_{RST}	250	610	1000	ms	
\overline{ST} Pulse Width	t_{ST}	20			ns	6, 9
V_{CC} Fail Detect to RST and \overline{RST}	t_{RPD}		50	175	μ s	
V_{CC} Slew Rate 4.75V to 4.25V	t_F	300			μ s	
V_{CC} Detect to RST and \overline{RST} Inactive	t_{RPU}	250	610	1000	ms	4
V_{CC} Slew Rate 4.25V to 4.75V	t_R	0			ns	
\overline{PBRST} Stable Low to \overline{RST} and RST	t_{PDLY}			20	ms	

NOTES:

- All voltages referenced to ground.
- Measured with outputs open and \overline{ST} and \overline{PBRST} within 0.5V of supply rails.
- \overline{PBRST} is internally pulled up to V_{CC} with an internal impedance of 40k typical.
- $t_R = 5 \mu$ s.
- \overline{RST} is an open-drain output.
- Must not exceed t_{TD} minimum. See Table 1.
- RST remains within 0.5V of V_{CC} on power-down until V_{CC} drops below 2.0V. \overline{RST} remains within 0.5V of GND on power-down until V_{CC} drops below 2.0V.
- Measured with outputs open and \overline{ST} and \overline{PBRST} at TTL levels.
- Watchdog can not be disabled. It must be strobed to avoid resets.

MARKING INFORMATION:

8-pin DIP - "DS1232L"

16-pin SOIC - "DS1232L"

8-pin SOIC - "DS1232L"

8-pin μ -SOP - "1232"

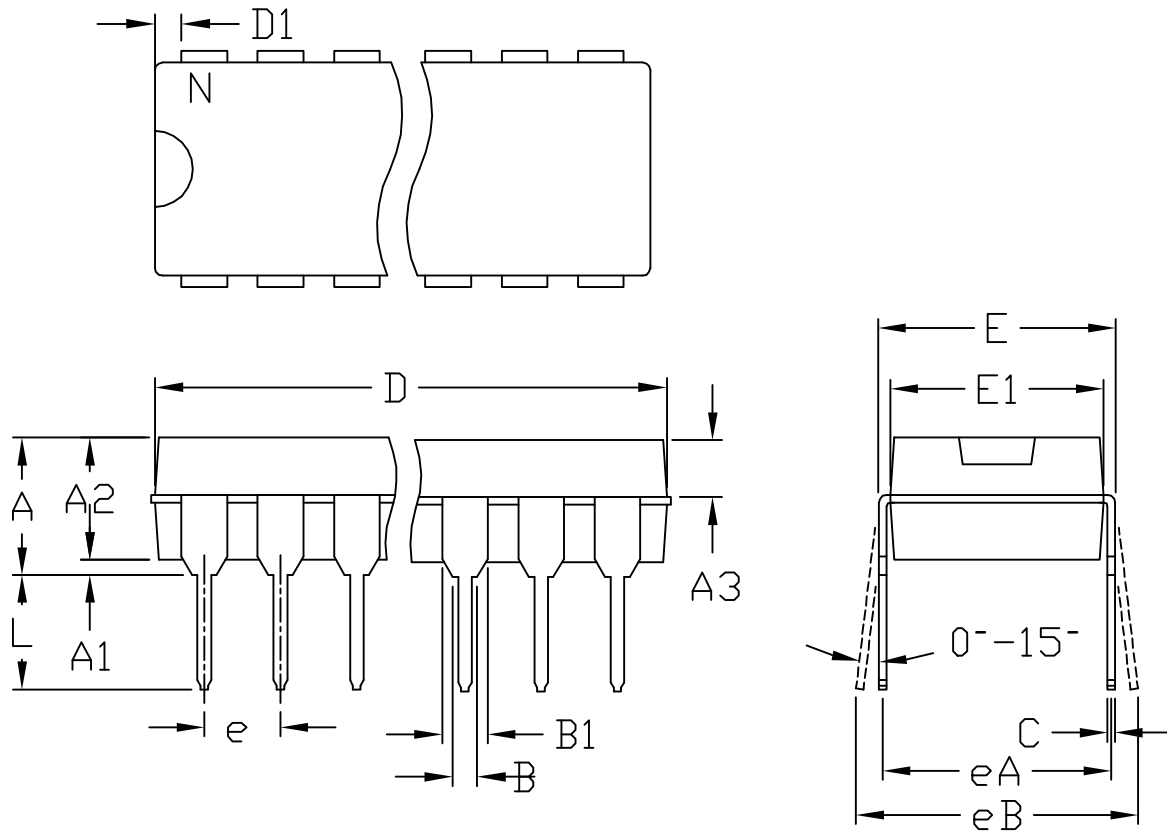

	INCHES		MILLIMETERS	
	MIN	MAX	MIN	MAX
A	---	0.180	---	4.572
A1	0.015	---	0.38	---
A2	0.125	0.175	3.18	4.45
A3	0.055	0.080	1.40	2.03
B	0.015	0.022	0.381	0.56
B1	0.045	0.065	1.14	1.65
C	0.008	0.014	0.2	0.355
D1	0.005	0.080	0.13	2.03
E	0.300	0.325	7.62	8.26
E1	0.240	0.310	6.10	7.87
e	0.100	BSC.	2.54	BSC.
eA	0.300	BSC.	7.62	BSC.
eB	0.400	BSC.	10.16	BSC.
L	0.115	0.150	2.921	3.81

	INCHES		MILLIMETERS		N	MS001
	MIN	MAX	MIN	MAX		
D	0.348	0.390	8.84	9.91	8	AB
D	0.735	0.765	18.67	19.43	14	AC
D	0.745	0.765	18.92	19.43	16	AA
D	0.885	0.915	22.48	23.24	18	AD
D	1.015	1.045	25.78	26.54	20	AE
D	1.14	1.265	28.96	32.13	24	AF
D	1.360	1.380	34.54	35.05	28	*5

- NOTES:
1. D&E DO NOT INCLUDE MOLD FLASH
 2. MOLD FLASH OR PROTRUSIONS NOT TO EXCEED .15mm (.006")
 3. CONTROLLING DIMENSION: MILLIMETER
 4. MEETS JEDEC MS001-XX AS SHOWN IN ABOVE TABLE
 5. SIMILIAR TO JEDEC MO-058AB
 6. N = NUMBER OF PINS