

HDM190HIRC2

Heavy Duty Mount, Mounting .1875" Max Torq 155 lb Max Dia for Washer .73"

PA66HIRHS, Black, 100/pkg

Article Number: 151-00134

Part Number: HDM190HIRC2

Type: HDM19

Material: PA66HIR



1. Base Data

Part No. HDM190HIRC2

Type HDM19

Color Black (BK)

Features The heavy duty mount and cable tie combination makes it easy to service bundles in the field. Simply remove the cable tie, leave the mount in place, and replace the cable tie. The heavy duty mounts are designed for use with HellermannTyton's heavy duty T

Application

The heavy duty mount, when used with a cable tie, eliminates the need to carry multiple sizes of fixed bundle diameter clamps, which reduces inventory and purchasing costs while simplifying the assembly process.

Application Method

These mounts contain a small tab inside the mounting hole to temporarily engage the threads, which allows assemblers to pre-install the mount on a stud before securing with a washer and a nut.

2. Product Dimensions

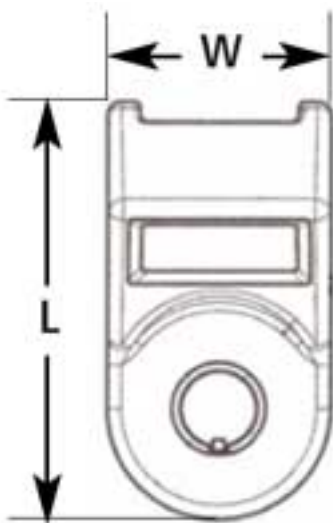

Length (L) 1.43 " / 36.32 mm

Width (W) .76 " / 19.3 mm

Max. Cable Tie Width 0.5 " / 12.7 mm

Width (W2) 13.3 mm

Height (H) 16.7 mm

Height (H2) 8.0 mm

Mounting Hole \emptyset .1875 " / 4.7

4. Material and Specifications

Material	Polyamide 6.6 high impact modified (PA66HIR)
Material Shortcut	PA66HIR
Flammability	UL94 HB
Max. Torque	132.5 kgf-cm / 9.583 lbf-ft
Operating Temperature	-40 °F to +176 °F (-40 °C to +80 °C) continuous

Logistic and Packaging

Packaging Type	bag
Pkg. Qty.	100
Carton Qty.	3000
UPC	08930617426

Mounts

Heavy Duty Mounts

The heavy duty mount, when used with a cable tie, eliminates the need to carry multiple sizes of fixed bundle diameter clamps, which reduces inventory and purchasing costs while simplifying the assembly process.

The heavy duty mount and cable tie combination makes it easy to service bundles in the field. Simply remove the cable tie, leave the mount in place, and replace the cable tie.

The heavy duty mounts are designed for use with HellermannTyton's heavy duty T250, T255, and wide strap cable ties to harness wires and hoses; however, they accept all standard cable ties up to .5" wide.

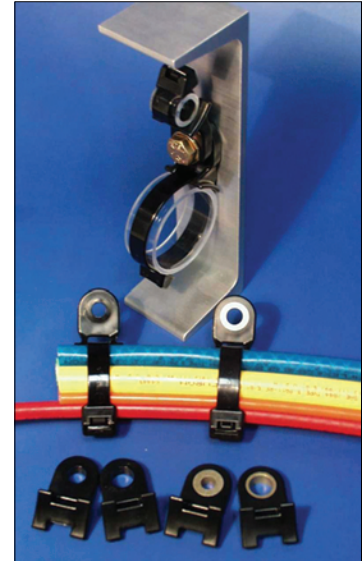

U.S. Patent Number 5,820,083

Material Data	
Material	Polyamide 6.6 impact modified, Heat Stabilized, UV Resistant (PA66HIRHS)
Operating Temperature	-40 °F to +230 °F (-40 °C to +110 °C) continuous
Flammability	UL94 HB



Standard Torque Mounts

These mounts contain a small tab inside the mounting hole to temporarily engage the threads, which allows assemblers to pre-install the mount on a stud before securing with a washer and a nut.

Product Selection		Type	Mounting	Max Torque	Max Ø for Washer/Socket	Length (L)	Width (W)	Color	Pkg. Qty.
Article No.	Part No.		in. (mm)	lb. - in	in. (mm)	in. (mm)	in. (mm)		
151-00134	HDM190HIRC2	HDM19	.1875 (4.8)	115 lb. - in.	.73" (18.5)	1.43" (36.32)	.76" (19.3)	Black	100
151-00436	HDM190HIRH4	HDM19	.1875 (4.8)	115 lb. - in.	.73" (18.5)	1.43" (36.32)	.76" (19.3)	Black	500
151-00437	HDM250HIRC2	HDM25	.25" (6.4)	115 lb. - in.	.73" (18.5)	1.43" (36.32)	.76" (19.3)	Black	100
151-00438	HDM250HIRH4	HDM25	.25" (6.4)	115 lb. - in.	.73" (18.5)	1.43" (36.32)	.76" (19.3)	Black	500
151-00439	HDM3120HIRC2	HDM312	.3125" (8)	115 lb. - in.	.73" (18.5)	1.43" (36.32)	.76" (19.3)	Black	100
151-00440	HDM3120HIRH4	HDM312	.3125" (8)	115 lb. - in.	.73" (18.5)	1.43" (36.32)	.76" (19.3)	Black	500

Dimensions are approximate and subject to technical changes. Use **Part No.** for ordering and **Type** for specification purposes.

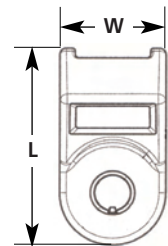

Medium Torque Mounts

The arched "H" profile of the saddle surface allows for a broad surface contact with the bundle, minimizing pinching and crushing of the bundles, and adjusts to a wide variety of bundle diameters.

Product Selection		Type	Mounting	Max Torque	Max Ø for Washer/Socket	Length (L)	Width (W)	Color	Pkg. Qty.
Article No.	Part No.		in. (mm)	lb. - ft.	in. (mm)	in. (mm)	in. (mm)		
151-00441	HDM321HIHSUVC2	HDM321	.3125" (8)	40 lb. - ft.	.90" (23)	1.8" (46)	.96" (24)	Black	100
151-07100	HDM321HIHSUVH4	HDM321	.3125" (8)	40 lb. - ft.	.90" (23)	1.8" (46)	.96" (24)	Black	500
151-00442	HDM401HIHSUVC2	HDM401	.375" (9.5)	40 lb. - ft.	.90" (23)	1.8" (46)	.96" (24)	Black	100
151-07300	HDM401HIHSUVH4	HDM401	.375" (9.5)	40 lb. - ft.	.90" (23)	1.8" (46)	.96" (24)	Black	500
151-00443	HDM501HIHSUVC2	HDM501	.5" (12.7)	40 lb. - ft.	.90" (23)	1.8" (46)	.96" (24)	Black	100
151-07500	HDM501HIHSUVH4	HDM501	.5" (12.7)	40 lb. - ft.	.90" (23)	1.8" (46)	.96" (24)	Black	500

Dimensions are approximate and subject to technical changes. Use **Part No.** for ordering and **Type** for specification purposes.

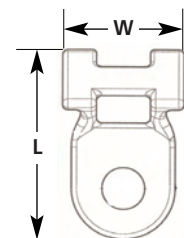

Heavy Duty Mounts (continued)

High Torque Mounts

The high torque mount is designed for use with power-assisted impact wrenches and is molded with a metal bushing to withstand the forces required to tighten grade 8 bolts. The arched "H" profile of the saddle surface allows for a broad surface contact with the bundle, minimizing pinching and crushing of bundles, and it adjusts to a wide variety of bundle diameters.

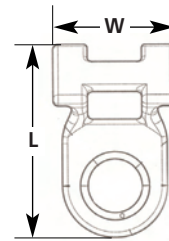

Product Selection									
Article No.	Part No.	Type	Mounting	Max Torque	Max Ø for Washer/Socket	Length (L)	Width (W)	Color	Pkg. Qty.
			in. (mm)	lb. - ft.	in. (mm)	in. (mm)	in. (mm)		
151-00444 151-07000	HDM320BHIHSUVC2 HDM320BHIHSUVH4	HDM320 HDM320	.3125" (8) .3125" (8)	114 lb. - ft. 114 lb. - ft.	.9" (23) .9" (23)	1.85" (47) 1.85" (47)	.99" (25) .99" (25)	Black Black	100 500
151-00445 151-07200	HDM400BHISHUVC2 HDM400BHIHSUVH4	HDM400 HDM400	.375" (9.5) .375" (9.5)	114 lb. - ft. 114 lb. - ft.	1.26" (32) 1.26" (32)	1.85" (47) 1.85" (47)	.99" (25) .99" (25)	Black Black	100 500
151-00446 151-07400	HDM500BHIHSUVC2 HDM500BHIHSUVH4	HDM500 HDM500	.5" (12.7) .5" (12.7)	114 lb. - ft. 114 lb. - ft.	1.26" (32) 1.26" (32)	1.85" (47) 1.85" (47)	.99" (25) .99" (25)	Black Black	100 500

Dimensions are approximate and subject to technical changes. Use **Part No.** for ordering and **Type** for specification purposes.

High Torque Double Mount

This mount is designed for use with power-assisted impact wrenches and is molded with a metal bushing to withstand the forces required to tighten grade 8 bolts. The high torque double mount secures the bundle directly over the mounting fastener. The cable ties are held in place during assembly with friction tabs inside the cable tie slots. The arched "H" profile of the saddle surface allows for a broad surface contact with the bundle, minimizing pinching and crushing of the bundles, and accommodates a wide variety of bundle diameters.

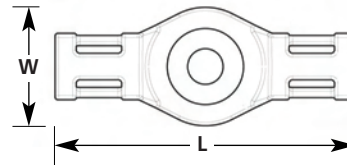

Product Selection									
Article No.	Part No.	Type	Mounting	Max Torque	Max Ø for Washer/Socket	Length (L)	Width (W)	Color	Pkg. Qty.
			in. (mm)	lb. - ft.	in. (mm)	in. (mm)	in. (mm)		
151-00456	151-00456	HDM375	.375" (9.5)	114 lb. - ft.	1.27" (32.5)	3.43" (87)	1.36" (34.5)	Black	100

Dimensions are approximate and subject to technical changes. Use **Part No.** for ordering and **Type** for specification purposes.