

## 175REF

.75" X .75" X 3.0" White Self-Laminating Vinyl, Refill for Rite-On Marker, 90/RL

Article Number: 590-01751

Part Number: 175REF

Type: 175REF

Material: 100

### 1. Base Data

---

<b>Part No.</b>	175REF
<b>Type</b>	175REF
<b>Color</b>	White
<b>Features</b>	HellermannTyton's refill Rite-On Markers are made from a flexible vinyl film and are used to mark wire and cable. The self-laminating labels have a clear tail which seals the legend under clear vinyl, maintaining the quality of the labels. The Rite-On m
<b>Application</b>	<b>Product Applications</b> - Telecom Installations - Residential Applications - Electrical Wiring
<b>Application Method</b>	Manual from label dispenser

Colour Marking Field	White
----------------------	-------

## 2. Product Dimensions

---

Length (L)	.750 " / 19.05
Width (W)	.750 " / 19.05
Height (H)	.750 " / 19.05 mm
Height (H2)	3.000 " / 76.20 mm
Min. Ø Bundle	.330 " / 8.32 mm
Max. Ø Bundle	.700 " / 17.78 mm
Min. Outside Ø	.330 "
Min. Diameter Ø	8.38
Max. Outside Ø	.700 " / 17.78
Min. Wire Size (in <sup>2</sup> )	.330 "
Wire Size Range (AWG)	4 to 4/0

## 4. Material and Specifications

---

Material	Type 100, self laminating Vinyl, white (WH)
Material Shortcut	100
Adhesive	Acryl / Acrylic
Adhesive Operating Temperature	-51 °F to +200 °F (-46 °C to +93 °C)
Curing Temperature	from +10 °C
Operating Temperature	-51 °F to +200 °F (-46 °C to +93 °C)
ROHS Conformity	

## Logistic and Packaging

---

<b>Packaging Type</b>	pack
<b>Pkg. Qty.</b>	90 / 90
<b>Carton Qty.</b>	1
<b>EAN code</b>	4031026172217
<b>Minimum Order Quantity</b>	90
<b>UPC</b>	08930612057

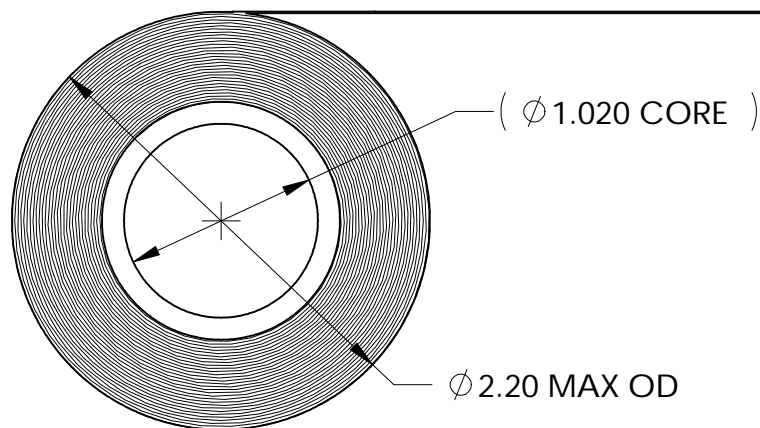
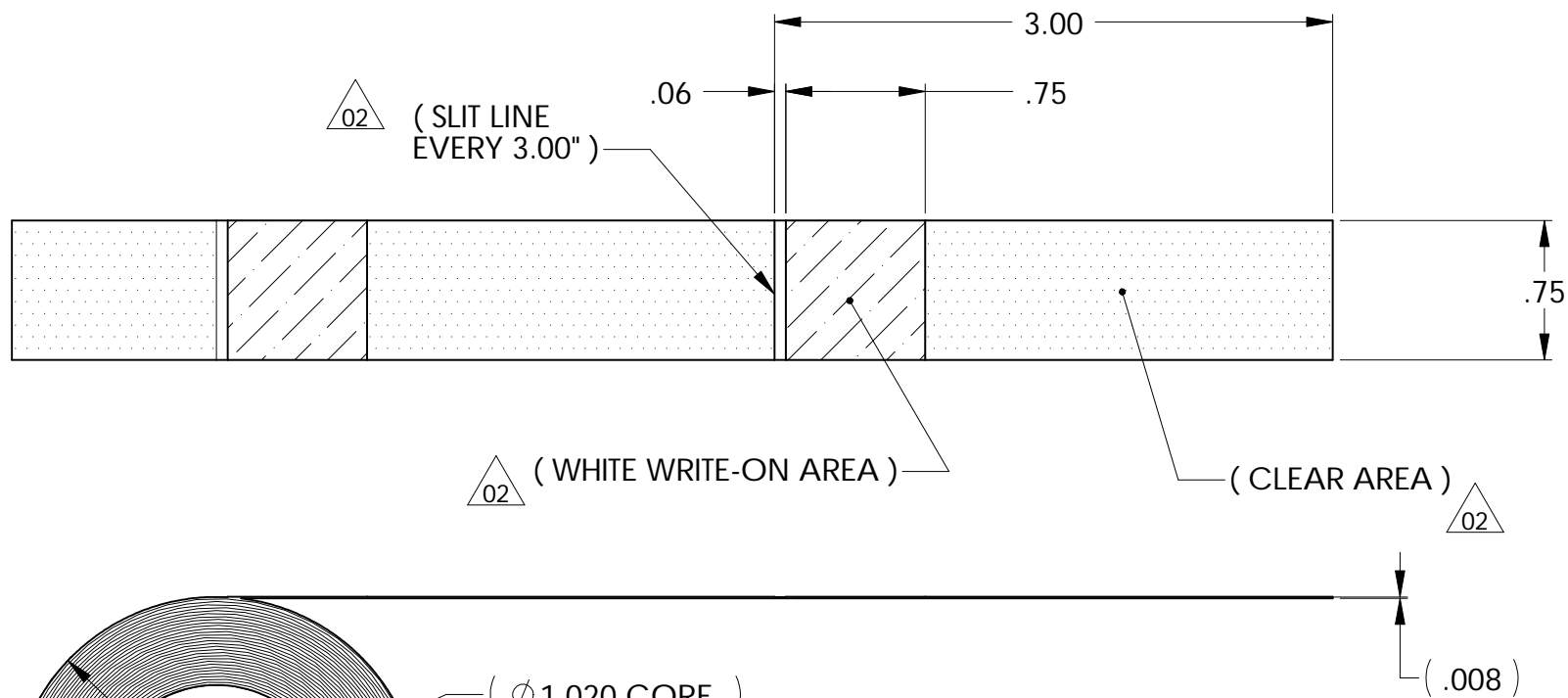

NOTE:  
02 1) 90 LABELS PER ROLL

INVENTORS

**HellermannTyton**

A SPIRENT Company

ALL PROPRIETARY RIGHTS IN THE SUBJECT MATTER SHOWN ON THIS DRAWING ARE EXCLUSIVE PROPERTY OF HELLERMANN TYTON

name	date	city, state

REVISION	level	02
	by	KAC
	date	2/5/03
	ECN #	003650
	part level	-

DIMENSIONS	TOLERANCES	.XXXX = $\pm$ .0005
		.XXX = $\pm$ .005
		.XX = $\pm$ .06
		.X = $\pm$ .03
		$\angle$ = $\pm$ 0.5°
	units	inches

PART	number	175REF	phase	PRODUCTION
	name			
	175REF RITE-ON MARKER REFILL ROLL			
	material			
	FLEXIBLE, VINYL FILM			

DRAWING	format version N	AH	CAD	SW	scale	1:1
	computer file number	LA2001003DTL_02				previous number
	drawn	K.A.C.	checked		approved	
		1/28/03	checked		approved	
	type	DETAIL			sheet 1 of 1	
	number	LA2001003DTL				

## Rite-On® Markers *continued*

### Refill Rolls

Product Selection			Width	Height of Write-On Area	Height of Label	Markers per Roll	Pkg. Qty.
Article No.	Part No.	Type	in. (mm)	in. (mm)	in. (mm)		
590-01011	<b>101REF</b>	101REF	.75 " (19.05)	.875 " (22.22)	6.0 " (152.4)	40	1 roll
590-01751	<b>175REF</b>	175REF	.75 " (19.05)	.75 " (19.05)	3.0 " (76.2)	40	1 roll
590-05121	<b>512REF</b>	512REF	.75 " (19.05)	.50 " (12.7)	1.875 " (47.62)	40	1 roll
590-05141	<b>514REF</b>	514REF	.75 " (19.05)	.375 " (9.52)	1.25 " (31.75)	40	1 roll

Dimensions are approximate and subject to technical changes. Use **Part No.** for ordering and **Type** for specification purposes.

### Nylon Marking Pens

When used with a non-smear FTP nylon marking pen, marking is fast and economical.

Product Selection				
Article No.	Part No.	Type	Color	Pkg. Qty.
500-50822	<b>T82-R</b>	T82R-RD	Red	2 pens
500-50820	<b>T82-S</b>	T82S-BK	Black	2 pens

Use **Part No.** for ordering and **Type** for specification purposes.



### Rite-On Marker Display

The Rite-On Marker point-of-purchase display helps ensure increased sales of this economical and popular labeling method.



Product Selection				
Article No.	Part No.	Type	Description	Pkg. Qty.
590-00000	<b>RODISPLAY</b>	RODISPLAY	Each display contains: - 12 dispensers (3 each of RO101, RO175, RO512 & RO514) - 6 starter packs (each pack contains an RO175 dispenser, a roll of labels, a pen and directions for use) - 16 refill rolls (4 each of the refill labels for each dispenser, 101REF, 175REF, 512REF & 514REF) - 1 wire stand display and header label.	1

Use **Part No.** for ordering and **Type** for specification purposes.