

I/O MODULES

Our line of pluggable input and output modules provide a low cost, versatile method for interconnecting real world analog and digital signals to data acquisition, monitoring, or control systems. All modules provide an optically isolated barrier between sensitive microprocessor or digital logic circuits and field power devices.

In the G5 and OpenLine® packages, analog and digital I/O modules are available with the same pin-out. This gives the flexibility of mixing and matching module types on the same mounting rack or base; making them perfect in applications which require interface to a variety of different sensors and loads.

The case color of the single point modules identify their function. The industry standard for single point I/O module case colors is:

- Digital AC Output Module = Black Case
- Digital DC Output Module = Red Case
- Digital AC Input Module = Yellow Case
- Digital DC Input Module = White Case

DIGITAL OUTPUT MODULES

Digital output modules are used to switch AC and DC loads such as solenoids, motors, or lamps from logic signal levels. Their inputs are directly compatible with TTL or CMOS interface circuitry.

AC output modules have zero voltage turn-on of the load to greatly reduce generated EMI and RFI. They are highly immune to electrical

transients, and have built-in RC snubber networks for increased capability with inductive loads.

DC output modules can operate DC loads over a wide voltage range and have built-in voltage spike protection.

DIGITAL INPUT MODULES

Digital input modules are used to monitor the status of a load or a sensor (such as a limit switch, pressure switch, or temperature switch). The output of these modules is a logic level signal which corresponds to the status of the device being monitored. A high level output signal indicates the load is off (the switch is open). A low level output signal indicates the load is on (the switch is closed). Input modules are designed to give fast, clean switching by providing filtering and hysteresis.

Input and output modules are compatible in that the output of one can drive the input of the other.

UL, CSA AND CE APPROVALS

As one of the world's leading manufacturers of I/O modules, we strive to assure that our products comply with all of the applicable international standards. In doing so, we believe your products will also be readily accepted and easily certified. All modules shown in this section have been tested to UL Standard 508 and are documented in UL file number E58632. Similarly, they have been tested to CSA

Standard 22.2 No. 14-95M and are documented in CSA file LR38763. Additionally, OpenLine® modules were tested and passed CSA 22.2 No. 213-M1987 Class I, Div. 2 Groups A, B, C and D. Parts bearing the CE logo indicate conformance with EN50082-2 and EN50081-2 (89/336/EEC EMC directive) as well as EN60950 (61010-1) for the low voltage directive. Contact Grayhill for copies of our Declaration of Conformity or visit our website. Parts bearing the TÜV logo indicate that they were the agency which performed the EN60950 evaluation.

CONSTRUCTION AND LIFETIME WARRANTY

All of our I/O modules are hard potted with thermally conductive epoxy to withstand harsh industrial environments. The modules provide optical isolation, immunity to mechanical shock and vibration, and operate over a wide temperature range. The module cases are a solvent resistant thermoplastic which meets UL94-V-0 rating. The terminal pins are a tin-plated copper wire. Component selection and surface mount construction allow low operating junction temperatures for long life. Superior design, rigorous testing, and field data give us the confidence to back our I/O modules with the industry's first lifetime warranty.

I/O MODULE WIRING

Analog and digital modules can be placed at any I/O location, however, to minimize the possibility of crosstalk and noise pickup it is a good practice to group similar module types together. 14 or 16 gauge wire is typically used to wire the field devices to the I/O rack terminal block.

PART NUMBER EXPLANATION: Digital I/O Modules

70M-ODC5A

| | | | |
|--------------------------------------|---|-----------------------------------|--------------------------|
| Module Type | | | |
| 70 | = | Digital Module, Standard Package | |
| 70G | = | Digital Module, G5 Package | |
| 70L | = | Digital Module, OpenLine® Package | |
| 70M | = | Digital Module, Mini Package | |
| Function | | | |
| OAC | = | Digital Output AC | |
| ODC | = | Digital Output DC | |
| IAC | = | Digital Input AC | |
| IDC | = | Digital Input DC | |
| Suffix | | | |
| AC Inputs: | Blank = 120 Vac | A = 220 Vac | |
| DC Inputs: | Blank = 3-32 Vdc | B = Fast Switching | NP = 15-32 Vac/10-32 Vdc |
| | G = 35-60 Vac/Vdc | D = 2.5-28 Vdc | K = 2.5-16 Vdc |
| | L = Inductive loads | S = Dry Contacts | |
| AC Outputs: | Blank = 120 Vac | A = 220 Vac | A-11 = Non-Zero Cross |
| | MA = 120 Vac, Manual Override | A-5 = Normally Closed | |
| | AMA = 240 Vac, Manual Override | | |
| DC Outputs: | Blank = 3-60 Vdc Fast | A = 4-200 Vdc R = Dry Contact | |
| | MA = 3-60 Vdc, Manual Override | B = 3-60 Vdc, Low Leakage | |
| Logic Supply Voltage or Range | | | |
| Digital Modules: | Blank = 4.5-28 Vdc (OpenLine®) | | |
| | 5 Vdc, 15 Vdc, 24 Vdc = Logic Supply Voltage (Standard, Mini, G5) | | |
| Analog Modules: | 4.75-5.25 Vdc | | |

DIMENSIONS: OpenLine® Digital Modules

Dimensions shown in inches (and millimeters).
Tolerances are ± .010 (0,25) unless indicated otherwise.

| Module Type | Output | Input |
|------------------|-------------|--------------|
| I/O Module Pin # | Function | Function |
| 1 | Output A+ | Input A+ |
| 2 | Output A- | Input A- |
| 3 | Output B+ | Input B+ |
| 4 | Output B- | Input B- |
| 5 | Logic Gnd | Logic Gnd |
| 6 | Vcc | Vcc |
| 7 | Ch. A Input | Ch. A Status |
| 8 | Ch. B Input | Ch. B Status |
| 9 | Module ID | Module ID |

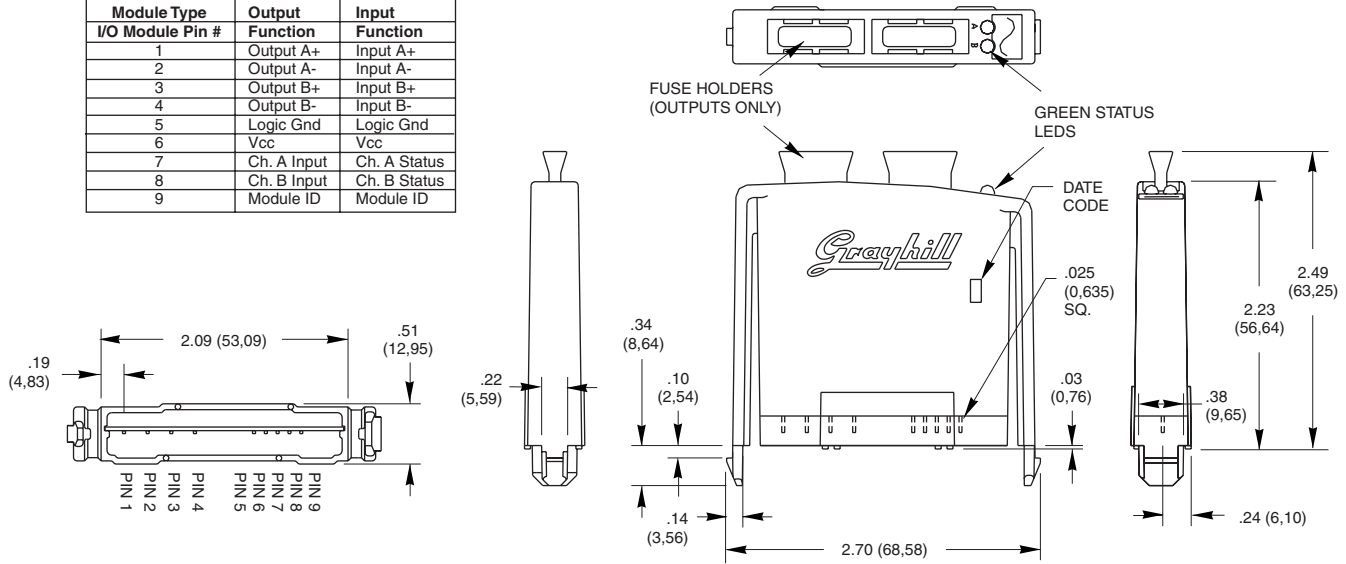

Note: For PC board layout information, request Bulletin #745

DIMENSIONS: G5 Digital Modules

Dimensions shown in inches (and millimeters).
Tolerances are ± .010 (0,25) unless indicated otherwise.

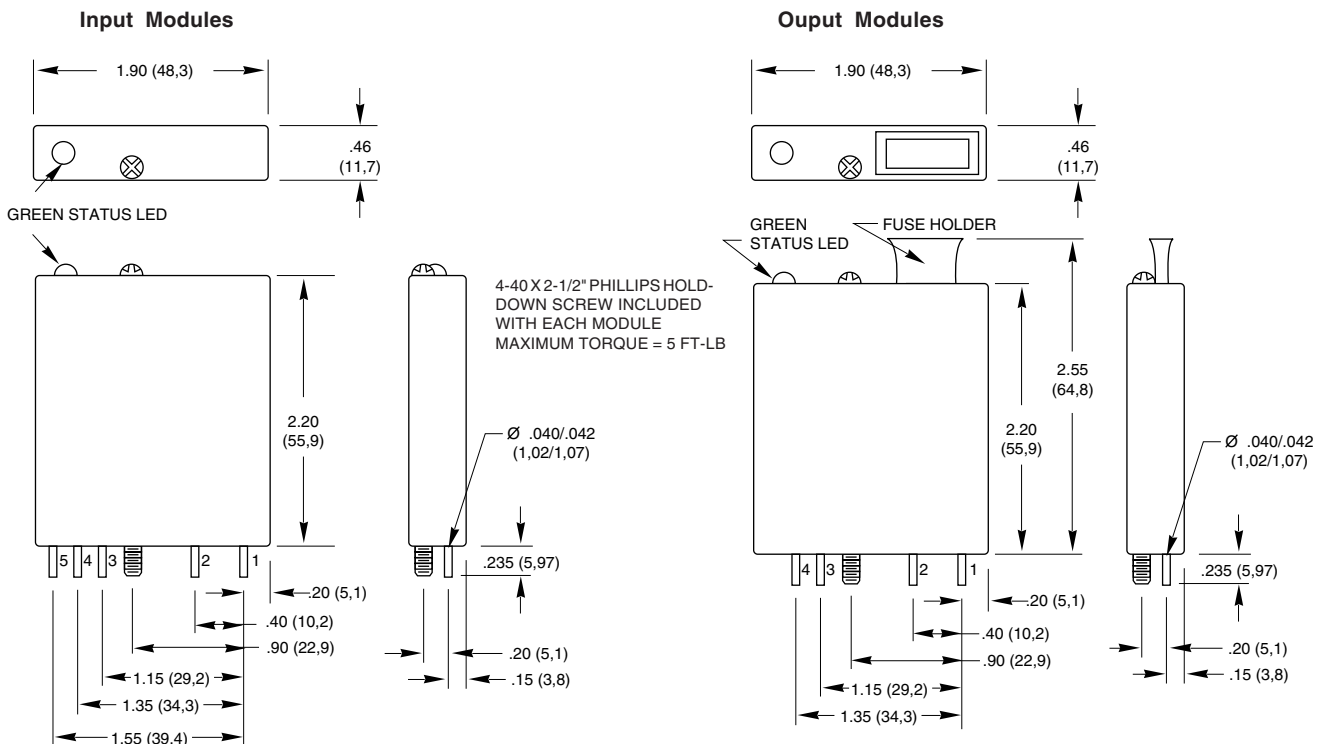

I/O Modules

DIMENSIONS: Standard and Miniature Digital Modules

Dimensions shown in inches (and millimeters).
Tolerances are $\pm .010$ (0,25) unless indicated otherwise.

Standard Module

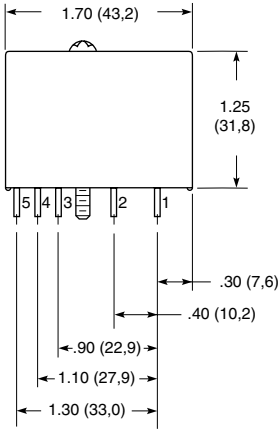
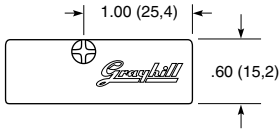

4-40 X 1-1/2" PHILLIPS HOLD-DOWN SCREW INCLUDED WITH EACH MODULE
MAXIMUM TORQUE = 5 FT-LB

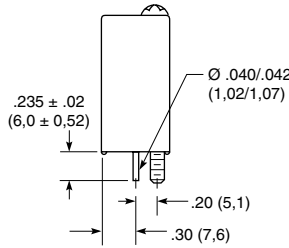

OUTPUT MODULES HAVE ONLY TERMINALS NUMBER 1-4

Miniature Module

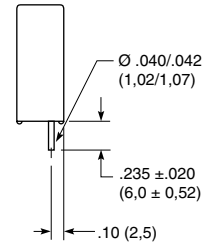
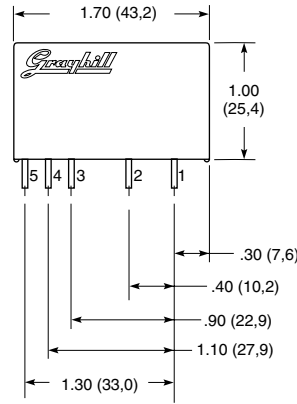
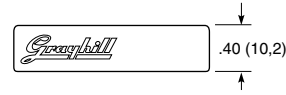

OUTPUT MODULES HAVE ONLY TERMINALS NUMBER 1-4

WIRING DIAGRAM: Digital I/O Modules

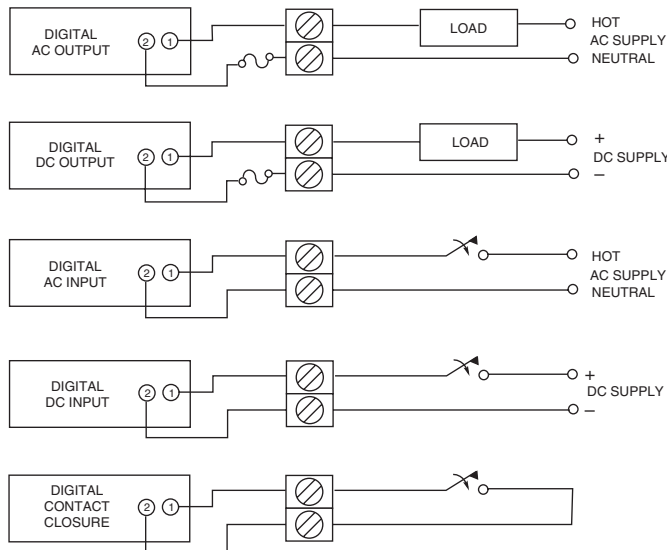

FEATURES

- Transient Protection: Meets the requirements of IEEE 472, "Surge Withstanding Capability Test"*
- Non-Polarized Types Provide Inputs For AC or DC
- UL, CSA, CE, TÜV Certified (TÜV not available on OpenLine)
- Optical Isolation
- OpenLine® and G5 Modules have Built-in Status LED



70L-IDC

70G-IDC

70-IDC

70M-IDC

CIRCUITRY

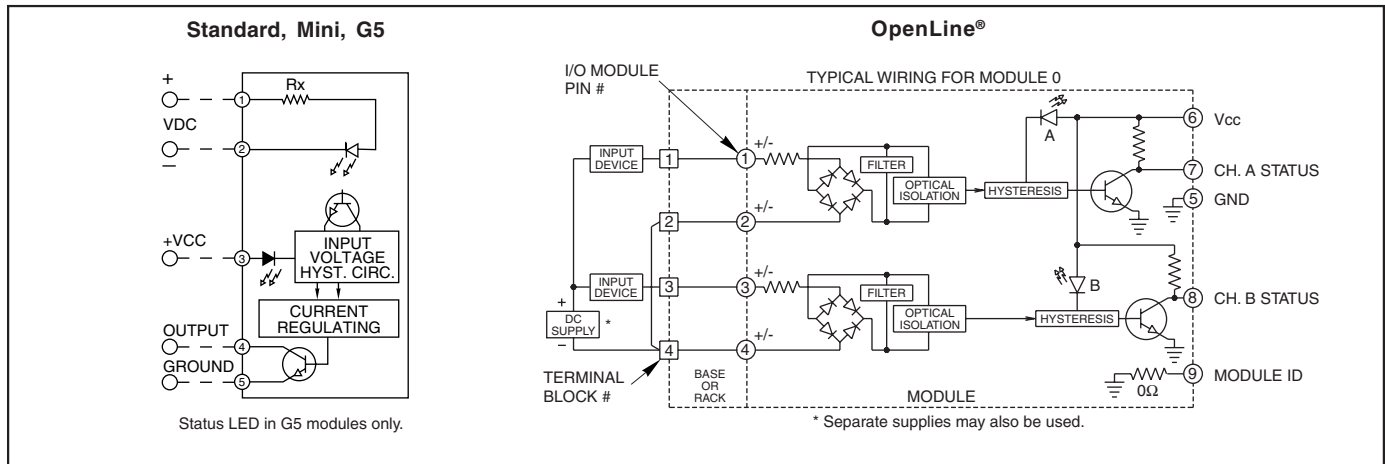

SPECIFICATIONS: By Package Style

| Package Style | | Std (70-) | Mini (70M-) | G5 (70G-) | OL (70L-) |
|--------------------------------|--------------|-------------|-------------|-------------|-------------|
| Specifications | Units | | | | |
| Output Current Range | mA | 1-50 | 1-50 | 1-50 | 1-50 |
| Min. Output Breakdown Voltage | Vdc | 50 | 50 | 50 | 50 |
| Isolation Voltage ¹ | Vrms | 4000 | 4000 | 4000 | 2500 |
| Vibration ² | | MIL-STD-202 | MIL-STD-202 | MIL-STD-202 | IEC68-2-6 |
| Mechanical Shock ³ | | MIL-STD-202 | MIL-STD-202 | MIL-STD-202 | IEC68-2-27 |
| Storage Temp. Range | °C | -40 to +125 | -40 to +125 | -40 to +125 | -40 to +100 |
| Operating Temp. Range | °C | -40 to +100 | -40 to +100 | -40 to +100 | -40 to +85 |
| Warranty | | Lifetime | Lifetime | Lifetime | Lifetime |

¹ Field to logic and channel-to-channel if Grayhill racks are used.

² MIL-STD-202, Method 204, 20 G, 10-2000 Hz or IEC68-2-6, 0.15 mm/sec², 10-150 Hz.

³ MIL-STD-202, Method 213, Condition F, 1500 G or IEC68-2-27, 11 mS, 15g.

SPECIFICATIONS: By Part Number
Standard and Miniature Modules

| Type/Function | | Grayhill Part Number | | | |
|--|---------|----------------------|-------------|-------------|-------------|
| Miniature, Non-Polarized | | 70M-IDC5G | 70M-IDC5NP | 70M-IDC15NP | |
| Standard, Non-Polarized | | 70-IDC5G | 70-IDC5NP | 70-IDC15NP | 70-IDC24NP |
| Specifications | Units | | | | |
| Maximum Input Voltage | Vac/Vdc | 60 | 32 | 32 | 32 |
| Input Voltage Range ¹ | Vac/Vdc | 35-60 | 15-32/10-32 | 15-32/10-32 | 15-32/10-32 |
| Input Current @ Max. Input Voltage | mA | 6 | 18 | 18 | 18 |
| Maximum Turn-on Time | mSec | 10 | 5 | 5 | 5 |
| Maximum Turn-off Time | mSec | 10 | 5 | 5 | 5 |
| Nominal Input Resistance (Rx) | Ω | 10K | 1.8K | 1.8K | 1.8K |
| Maximum Pick Up Voltage (Output Low) | Vac/Vdc | 35 | 15/10 | 15/10 | 15/10 |
| Minimum Drop Out Voltage (Output High) | Vac/Vdc | 9 | 3 | 3 | 3 |
| Nominal Logic Voltage (Vcc) | Vdc | 5 | 5 | 15 | 24 |
| Logic Voltage Range | Vdc | 3-6 | 3-6 | 8-18 | 15-30 |
| Max. Logic Supply Current @ Nominal Vcc | mA | 10 | 10 | 10 | 10 |

G5 Modules

| Type/Function | | Grayhill Part Number | | | |
|--|---------|----------------------|-------------|-------------|-------------|
| G5, Non-Polarized, Status LED | | 70G-IDC5G | 70G-IDC5NP | 70G-IDC15NP | 70G-IDC24NP |
| Specifications | Units | | | | |
| Maximum Input Voltage | Vac/Vdc | 60 | 32 | 32 | 32 |
| Input Voltage Range ¹ | Vac/Vdc | 35-60 | 15-32/10-32 | 15-32/10-32 | 15-32/10-32 |
| Input Current @ Max. Input Voltage | mA | 6 | 18 | 18 | 18 |
| Maximum Turn-on Time | mSec | 10 | 5 | 5 | 5 |
| Maximum Turn-off Time | mSec | 10 | 5 | 5 | 5 |
| Nominal Input Resistance (Rx) | Ω | 10K | 1.8K | 1.8K | 1.8K |
| Maximum Pick Up Voltage (Output Low) | Vac/Vdc | 35 | 15/10 | 15/10 | 15/10 |
| Minimum Drop Out Voltage (Output High) | Vac/Vdc | 9 | 3 | 3 | 3 |
| Nominal Logic Voltage (Vcc) | Vdc | 5 | 5 | 15 | 24 |
| Logic Voltage Range: Std & Mini | Vdc | 4.5-6 | 4.5-6 | 10-18 | 17-30 |
| Max. Logic Supply Current @ Nominal Vcc | mA | 10 | 10 | 10 | 10 |

OpenLine® Modules

| Type/Function | | Grayhill Part Number | |
|--|---------|----------------------|-------------|
| Dual, Non-Polarized, Status LED | | 70L-IDCG | 70L-IDCNP |
| Specifications | Units | | |
| Maximum Input Voltage | Vac/Vdc | 60 | 32 |
| Input Voltage Range ¹ | Vac/Vdc | 35-60 | 15-32/10-32 |
| Input Current @ Max. Input Voltage | mA | 6 | 17 |
| Maximum Turn-on Time | mSec | 10 | 5 |
| Maximum Turn-off Time | mSec | 10 | 5 |
| Nominal Input Resistance (Rx) | Ω | 10.6K | 1.9K |
| Maximum Pick Up Voltage (Output Low) | Vac/Vdc | 35 | 15/10 |
| Minimum Drop Out Voltage (Output High) | Vac/Vdc | 9 | 3 |
| Nominal Logic Voltage (Vcc) | Vdc | 5 | 5 |
| Logic Voltage Range | Vdc | 4.5-28 | 4.5-28 |
| Max. Logic Supply Current @ Nominal Vcc | mA | 6/CH | 6/CH |
| Module ID Resistance to Logic Ground | Ω | 0 | 0 |

Available from your local Grayhill Distributor.
 For prices and discounts, contact a local Sales
 Office, an authorized local Distributor or Grayhill.

¹ For input voltages in the range of 90 to 140 Vdc, use AC input modules 70-IAC5, 70M-IAC5, 70G-IAC5 or 70L-IAC. For input voltages in the range of 180 to 280 Vdc, use AC input modules 70-IAC5A, 70M-IAC5A, 70G-IAC5A or 70L-IAC5A.