

FEATURES

- Wire Dry Contact Sensors Directly to Module, Eliminate External Power Supply
- 2500 Vac Isolation
- Built-In Status LED
- UL, CSA, CE Mark, TÜV Certified (TÜV not available on OpenLine®)
- Simplifies Field Wiring

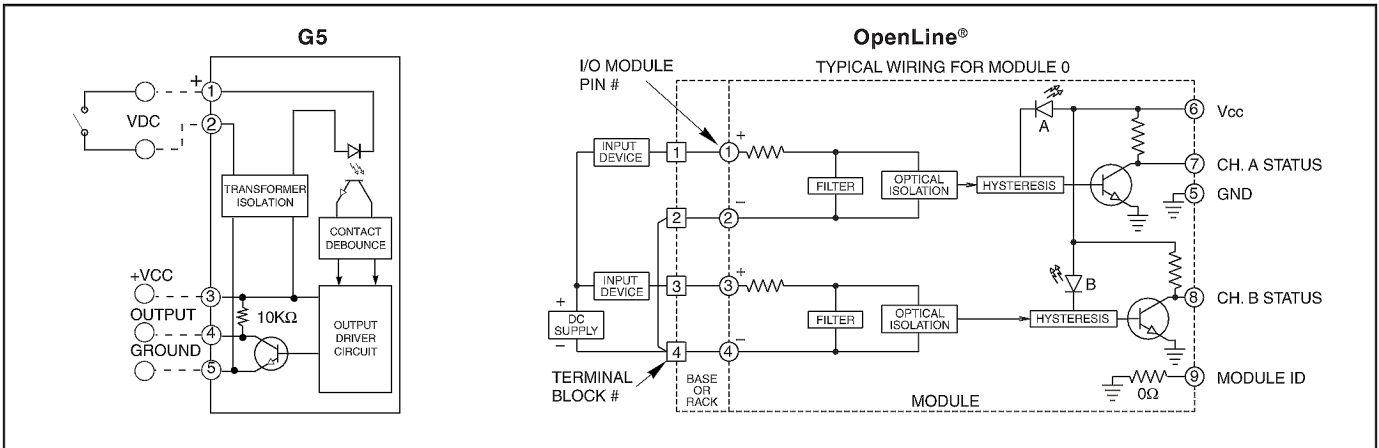

CIRCUITRY: Negative True Logic



SPECIFICATIONS:

Specifications apply over operating temperature range unless noted otherwise.

All Modules

Output Specifications

- Output Current Range:** 1-50 mA
- Breakdown Voltage:** 50 Vdc minimum
- Off State Leakage Current:** 1 µA maximum
- On State Voltage Drop:** 0.45 Vdc at 50 mA maximum

General Characteristics

Isolation Voltage Field to Logic:
2500 Vac (rms) minimum

OpenLine®

- Vibration:** .15ms, 10 to 50 Hz per IEC68-2-6
- Mechanical Shock:** 50 G's, 0.5 ms, sinusoidal per IEC68-2-27
- Storage Temperature Range:** -40°C to +100°C
- Operating Temperature Range:** -40°C to +85°C

G5

- Vibration:** 20 G's peak or .06" double amplitude 10–2000 Hz per MIL–STD–202, Method 204, Condition D
- Mechanical Shock:** 1500 G's 0.5 ms half-sine

per MIL–STD–202, Method 213, Condition F

Storage Temperature Range:

-40°C to +125°C

Operating Temperature Range:

0°C to +60°C

Available from your local Grayhill Distributor.
For prices and discounts, contact a local Sales Office, an authorized local Distributor or Grayhill.

SPECIFICATIONS: By Part Number

Type/Function		Grayhill Part Number		
G5, Dry Contact		70L-IDC5S	70G-IDC5S	70G-IDC24S
Specifications	Units			
Maximum Dry Contact Voltage Rating	Vdc	25	25	25
Minimum Dry Contact Current Rating	mA	5	5	5
Maximum Turn-on Time	mSec	10	3.0	3.0
Maximum Turn-off Time	mSec	10	3.0	3.0
Contact Resistance (Output Low)	Ω	≤ 1.25K	≤1.25K	≤ 1.25K
Contact Resistance (Output High)	Ω	25K	25K	25K
Nominal Logic Voltage (Vcc)	Vdc	5	5	24
Logic Voltage Range: G5	Vdc	4.5-5.5	4.5-6	15-30
Max. Logic Supply Current @ Nominal Vcc	mA	120 ¹	41	41

¹WHEN BOTH CHANNELS ARE ACTIVATED

ANALOG I/O MODULES

Analog output modules are used in proportional control of devices such as valves, motors, and heaters. Analog input modules are used in data gathering and proportional control applications.

All modules are potted for industrial environments. They operate under high vibration (IEC68-2-6; 0.15 mm/sec² at 10-150Hz) mechanical shock (IEC68-2-27; 11 mS, sinusoidal 30 gS) and high relative humidity (IEC68-2-3; 5-95% non-condensing). They feature a high level of noise immunity and accuracy. All models provide isolation from field to logic, field to power supply and module to module.

OpenLine® Analog

OpenLine® analog modules communicate serially with the controller. Each module has a separate transmit and receive line that operates at 115,200 baud with no parity bits, 8 data bits, and 1 stop bit (115.2K,N,8,1). The command structure and responses for all modules are detailed in Bulletin No. 743. Each module has a microcontroller and non-volatile serial EEPROM memory. The calibration data is stored within the EEPROM, and may be changed using the appropriate commands and the 70L-PROG field calibration unit. The software provided with the calibration unit communicates with the modules through the serial port of a PC. Calibration equipment is not provided.

OpenLine® Analog Input Modules

Upon request, analog input modules return a

12-bit value that is right justified and packed in a 16-bit word that represents the equivalent analog value sensed.

OpenLine® thermocouple inputs linearize the thermocouple reading and returns degrees to the controller.

Openline® Analog Output

For analog output modules, the output of these modules is zero scale on power up, then it is the analog equivalent of the 12-bit value sent to the module over the communication lines.

G5 Analog Output

The output (voltage or current level) of these modules varies proportionally to the 12-bit serial data string sent to them by a control circuit. The data string is typically 213.2 µSec. long as detailed in Figure 1. Once a data string is received, the output is set and remains constant until another data string is sent. Therefore, the output level of the module could be changed almost 4700 times a second.

For more information on programming Grayhill analog output modules, request a copy of Bulletin No. 581.

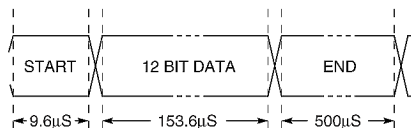

Figure 1

Start Pulse: High for 6.4 µS Min., then low for 3.2 µS

Data Packet: Each bit is 12.8 µS long.

High for first 3.2 µS of the bit.

Middle 6.4 µS determines the value of the data bit (High = 1, Low = 0).

Low for last 3.2 µS of the bit.

Stop Pulse: Low for 500 µS minimum

Times shown are ± 10%, except minimums.

SERIAL DATA FORMAT**

G5 Analog Input

G5 voltage or current input modules are actually frequency converters. The input to these modules is a signal from a sensor. The output from these modules is a squarewave whose frequency varies linearly from 14.4 to 72 KHz and is proportional to the input signal. The controller must be able to measure this frequency and convert it back to a signal level.

G5 thermocouple modules pass through the thermocouple reading and do not linearize the signal. Linearization must take place within the controller.

Agency Approvals

OpenLine® analog modules are EN50082-2 and EN50081-2 compliant and meet the requirements of 89/336/EEC EMC directive. They are also EN60950 (61010-1) compliant. Meeting these requirements allows the modules to bear the CE mark. Additionally, the modules are CSA certified to CSA 22.2 No. 14-95M and CSA 22.2 No. 213-M1987 Class I, Div. 2 Groups A, B, C and D and are UL recognized to UL 508.

PART NUMBER EXPLANATION: Analog I/O Modules

Module Type
 73G = Analog Module, G5 Package, Single Channel
 73L = Analog Module, OpenLine® Package, Dual Channel

Function
 OV = Analog Output, Voltage II = Analog Input, Current
 OI = Analog Output, Current IT = Analog Input, Temperature
 IV = Analog Input, Voltage

Suffix

Analog Modules:	5 = 0-5 Vdc	10 = 0 - 10 Vdc	50M = 0-50 mV
	5B = -5-5 Vdc	10B = -10 - 10 Vdc	100M = 0-100 mV
	1 = 0-1 Vdc	020 = 0 to 20 mA	R100 = RTD
	CJ = J type TC	420 = 4 to 20 mA	R3100 = 3 Wire RTD
	CK = K type TC	5000 = 0 to 5 A	R4100 = 4 Wire RTD
	CR = R type TC	AC120 = 28 to 140 Vac	
	CT = T type TC	AC240 = 28 to 280 Vac	

I/O Modules

I/O
21