

*RoHS COMPLIANT

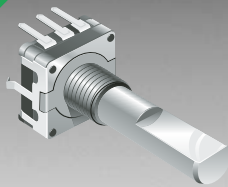

BOURNS®

Features

- Push switch option
- Compact, rugged design
- High reliability
- Metal bushing/shaft

Applications

- Level control, tuning and timer settings in:
- Audio-visual equipment
 - Consumer electric appliances
 - Radios
 - Musical instrumentation
 - Communications equipment

PEC11 Series - 12 mm Incremental Encoder

Electrical Characteristics

Output	2-bit gray code
Closed Circuit Resistance	3 ohms maximum
Contact Rating	1 mA @ 5 VDC
Insulation Resistance	100 megohms @ 250 VDC
Dielectric Withstanding Voltage	
Sea Level	300 VAC minimum
Electrical Travel	Continuous
Contact Bounce (15 RPM)	5.0 ms maximum
RPM (Operating)	60 maximum

Environmental Characteristics

Operating Temperature Range	-30 °C to +70 °C (-22 °F to +158 °F)
Storage Temperature Range	-40 °C to +85 °C (-40 °F to +185 °F)
Humidity	MIL-STD-202, Method 103B, Condition B
Vibration	30 G
Contact Bounce	10~55~10 Hz / 1 min. / Amplitude 1.5 mm
Shock	100 G
Rotational Life	30,000 cycles minimum
Switch Life	20,000 cycles minimum
IP Rating	IP 40

Mechanical Characteristics

Mechanical Angle	360 ° continuous
Torque	
Running	50 to 200 gf.cm (0.68 to 2.7 oz.-in.)
Mounting	10.2 kgf.cm (8.83 lb.-in.) maximum
Shaft Side Load (Static)	2.04 kgf (4.5 lbs.) minimum
Weight	5 gm (0.17 oz.) maximum
Terminals	Printed circuit board terminals
Soldering Condition	
Wave Soldering	Sn95.5/Ag2.8/Cu0.7 solder with no-clean flux: 260 °C max. for 3-5 seconds
Hand Soldering	Not recommended
Hardware	One flat washer and one mounting nut supplied with each encoder.

Switch Characteristics

Switch Type	Contact Push ON Momentary SPST
Power Rating (Resistive Load)	10 mA at 5 V DC
Switch Travel	0.5 ± 0.2 mm
Switch Actuation Force	610 ± 306 gf (8.47 ± 4.24 oz.-in.)

How To Order

PEC11 - 4 0 20 F - S 0012

Model	PEC11
Terminal Configuration	4 = PC Pin Horizontal/Rear Facing
Detent Option	0 = No Detents (12, 18, 24 pulses) 1 = 18 Detents (18 pulses) 2 = 24 Detents (12, 24 pulses)
Standard Shaft Length	15 = 15.0 mm 20 = 20.0 mm 25 = 25.0 mm 30 = 30.0 mm
Shaft Style	F = Metal Flatted Shaft K = Metal Knurled Shaft*
Switch Configuration	S = Push Momentary Switch N = No Switch
Resolution	0012 = 12 Pulses per 360 ° Rotation 0018 = 18 Pulses per 360 ° Rotation 0024 = 24 Pulses per 360 ° Rotation

Quadrature Output Table

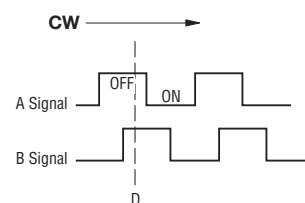

* Metal knurled shaft with no switch is available in 15, 20 and 30 mm shaft lengths.
Metal knurled shaft with push momentary switch is available in 15 and 20 mm shaft lengths.

*RoHS Directive 2002/95/EC Jan 27 2003 including Annex
Specifications are subject to change without notice.
Customers should verify actual device performance in their specific applications.

PEC11 Series - 12 mm Incremental Encoder

BOURNS®

Product Dimensions

PEC11-4xxxF-Nxxxx

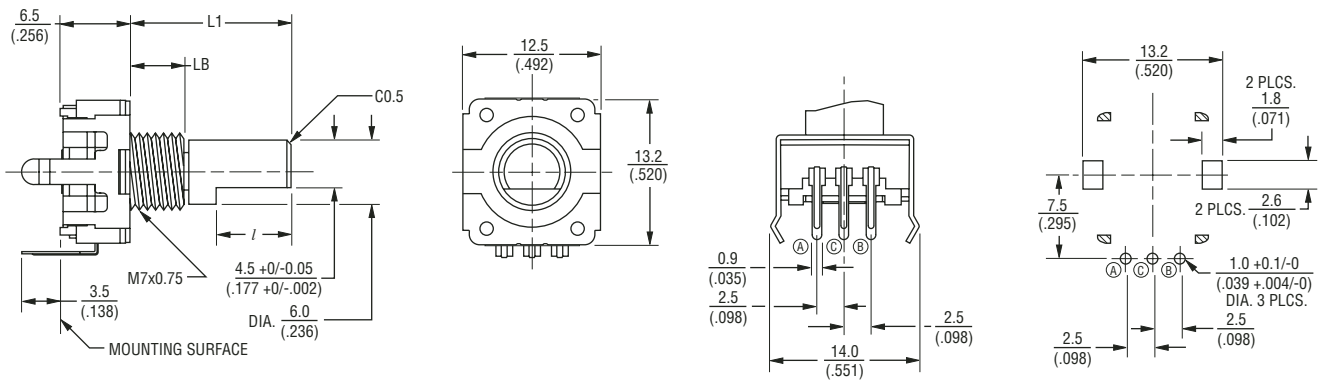

PEC11-4xxxF-Sxxxx

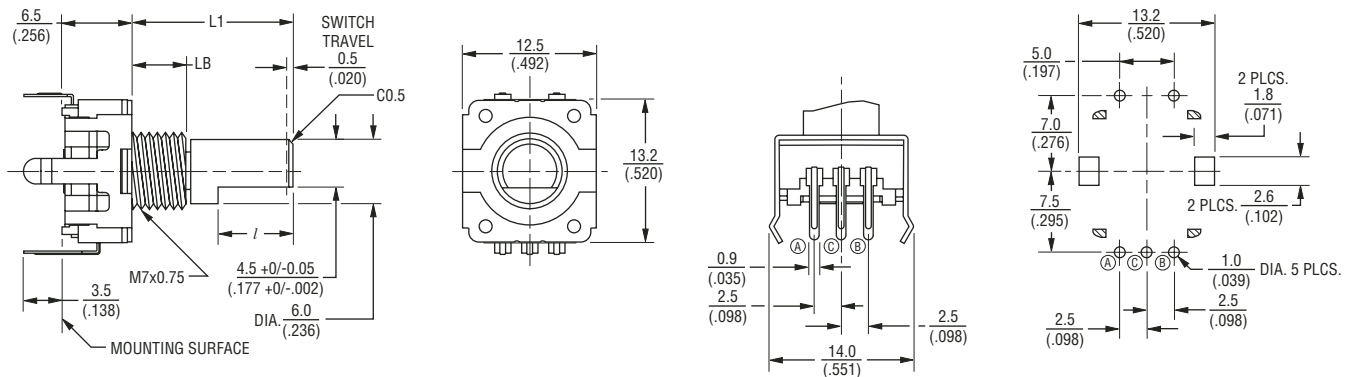

L1	LB	l
15 (.591)	5.0 (.197)	7.0 (.276)
20 (.787)	7.0 (.276)	10.0 (.394)
25 (.984)	7.0 (.276)	12.0 (.472)
30 (1.181)	7.0 (.276)	12.0 (.472)

DIMENSIONS: $\frac{\text{MM}}{\text{(INCHES)}}$

PEC11 Series - 12 mm Incremental Encoder

BOURNS®

Product Dimensions

PEC11-4xxxK-Nxxxx

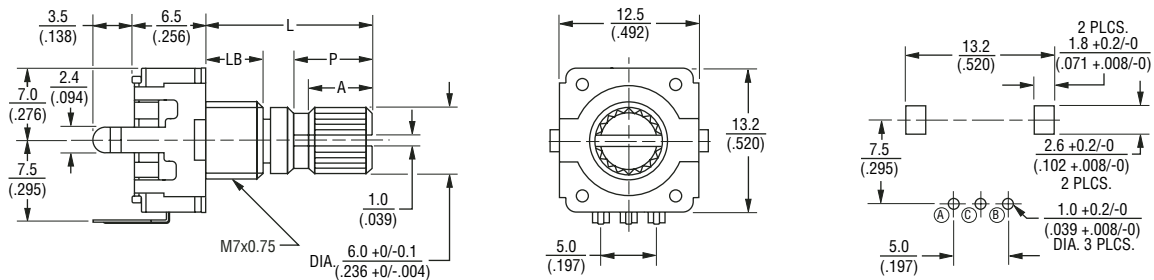

L	LB	P	A
15 (.591)	5.0 (.197)	7.0 (.276)	6.0 (.236)
20 (.787)	7.0 (.276)	7.0 (.276)	6.0 (.236)
30 (1.181)	7.0 (.276)	16.0 (.630)	12.0 (.472)

PEC11-4xxxK-Sxxxx

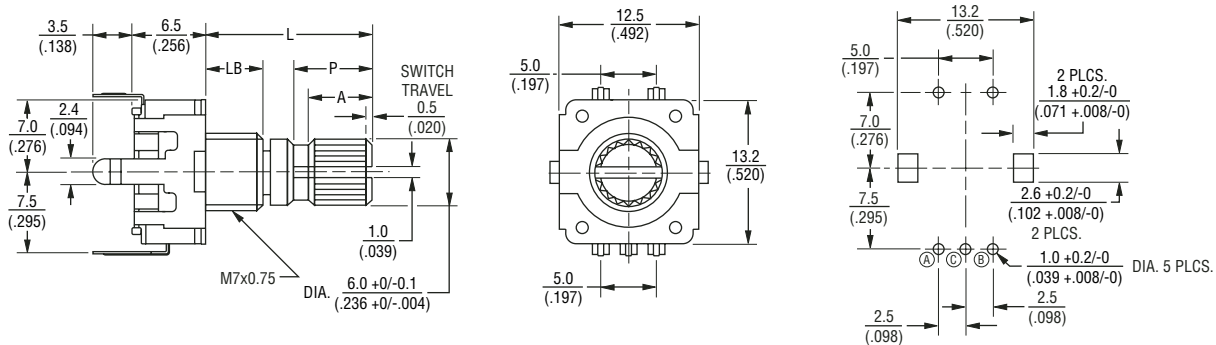

L	LB	P	A
15 (.591)	5.0 (.197)	7.0 (.276)	6.0 (.236)
20 (.787)	7.0 (.276)	7.0 (.276)	6.0 (.236)

DIMENSIONS: $\frac{\text{MM}}{\text{(INCHES)}}$