

C-Range Infrared Window

Increase the safety
& speed of electrical
thermography

If you are concerned about arc-flash but wish to continue with your infrared thermography program, infrared windows are the answer. These arc-resistant, outdoor certified, infrared windows allow thermal, ultraviolet, visual and fusion technologies to be used without exposing personnel to live equipment.

All infrared windows from Hawk IR International use the unique **Quadraband™** multispectral optic, allowing inspection with any camera for total flexibility both now and in the future.

- Engineered and tested to withstand electric-arcs up to 50kA for 30 cycles.
- Certified by UL & CSA for Type 3/12 (Outdoor) environments in North America and Canada, the C-Range windows are tested to withstand the long term aging effects of UV exposure.
- Certified by SIRA Certification IP65 (Outdoor) environments in Europe.
- The CLIRVU® coating – exclusive to Hawk IR Windows - seals the optic prior to assembly to protect against moisture degradation.
- Own a Fluke Camera? The Quadraband™ optic is IR-Fusion® compatible, allowing the thermographer to see potential problems in visual light and thermographic mode.
- Got more than one window per panel? Each C-Range window is delivered with an identification plate attached for unique, on-site numbering for rapid location confirmation and faster repairs.
- Each infrared window comes complete with a security access key, installation instructions and self-adhesive drilling template.



Do you have an infrared camera with IR fusion capability? Do you simply want to take a digital photograph of a problem to help with a repair? Using pre-shot digital pictures of switchgear attached to outdoor panels is never a long term, robust solution.

With C-Range Quadraband™ optics you can use the same IR Window to confirm a disconnect position, clarify a phase color in a multicable feeder or even visually detect discoloration as further confirmation of a problem.

Detailed specifications

	FLK-050-CL / CLKT	FLK-075-CL / CLKT	FLK-100-CL / CLKT
Optic Data			
Crystal Insert Diameter	50 mm (1.97 in)	75 mm (2.96 in)	100 mm (3.94 in)
Viewing Aperture Diameter	43 mm (1.7 in)	68 mm (2.7 in)	89 mm (3.5 in)
Viewing Aperture Area	1452 mm ² (2.25 sq in)	3632 mm ² (5.63 sq in)	6322 mm ² (9.79 sq in)
Thickness	2 mm (0.08 in)	2 mm (0.08 in)	4 mm (0.16 in)
CLIRVU Coating	Yes		
Shortwave IR Capable	Yes		
Midwave IR Capable	Yes		
Longwave IR Capable	Yes		
Ultraviolet (UV) Capable	Yes		
Visual Capable	Yes		
Fusion Capable	Yes		

Why is available area important?

Understanding the difference between "Optic Diameter" and "Available Area" gives the thermographer a measure of how much infrared energy is passing through the window. The more energy, the better the reading. Using a crystal IR Window means that the entire area is available for infrared transmission for

optimum repeatability and results. While a mesh grid may have a larger "Optic Diameter" the grid itself blocks the IR signal, meaning that the amount of radiation available to the camera is significantly reduced and the signal may be irregular.

Underwriters Laboratories (UL) Recognized	YES
UL50 Environmental	Type 3/12
UL746C	N/A (Polymer Free)
UL94	N/A (Polymer Free)
Canadian Standards Association (CSA) Approval	YES
Environmental	Type 3/12
KEMA (Arc-Testing)	
ANSI C37.20.7	50 kA for 30 cycles @60 Hz
EEMACS 14-1 Type-B	40 kA for 30 cycles @60 Hz
ASTA (Arc-Testing)	
IEC 62271	20 kA for 5 cycles @50 Hz
TUV	
Cyclic Humidity Withstand	YES
Vibration Withstand	YES
NEMKO	
Resistance of insulating materials to 100°C	YES
Resistance of insulating material to ball pressure (Brinell)	YES
Glow-wire test 650 °C	YES
Lloyds Register	
Up to 11kV Marine Switchgear, Indoor or Outdoor	YES

General specifications

Maximum Temperature	Gaskets: 250 °C (482 °F)
	Body: 659 °C (1219 °F)
	Optic: 1400 °C (2552 °F)
Gaskets	Low Smoke & Fume (LSF) compliant silicone
IP Rating	IP65
NEMA Rating	Type 3/12 (UL & CSA Third Party Certified)
Vibration Rating	IEC60068-2-6
Humidity Rating	IEC60068-2-3
Pull-out strength	Up to 630 kg (1388 lb)
Warranty	Lifetime replacement against manufacturing defects

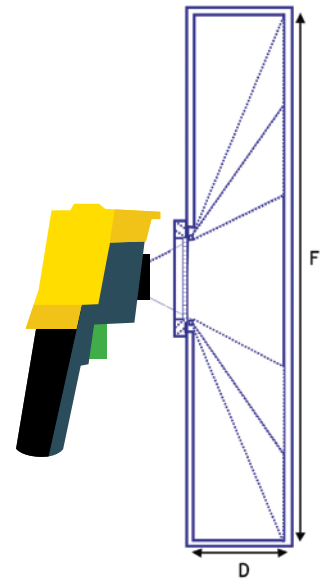

Basic Field of View (FOV) calculation, $F = 6 \times D$

Ordering information

Crystal Insert Size	50 mm (2 in)	75 mm (3 in)	100 mm (4 in)
	FLK-050-CL	FLK-075-CL	FLK-100-CL
Standard Aluminium Cover	-	-	-
Kwik-Twist Aluminium Cover	KT	KT	KT

Included with product

IR Windows are supplied complete, assembled and ready for installation. In addition to the IR Window each carton contains: Installation CD, self-adhesive drilling template, security access key, warranty statement.

Example part number for 4 – inch C-Range with kwik-twist aluminium cover = FLK-100-CLKT

Distributed by



Hawk IR International Inc.
 1500 N. Greenville Ave
 Richardson
 TX 75081, USA
 Toll Free:- 877-4-HAWKIR
 Email. sales.us@hawk-ir.com
 Web. www.irwindows.com

Hawk IR International Ltd.
 117 High Street
 Marske
 North Yorkshire TS11 6JX
 United Kingdom
 Tel. +44 (0) 1642 497000
 Email. sales@hawk-ir.com
 Web. www.hawksightglasses.com