



## CeraDiode

SMD type, single, case size 0402, 0603 and 1003

<b>Series/Type:</b>	<b>CDS*C**GTA</b>
<b>Ordering code:</b>	<b>B725**D****A***</b>
Date:	2007-02-20
Version:	3

## Reliable ESD protection of single lines



### Description

Due to the ongoing miniaturization, today's electronic devices are more and more sensitive to electrostatic discharges (ESD). Therefore reliable protection components become absolutely necessary to safeguard your valuable electronics against the impact of ESD.

CeraDiodes are ceramic semiconductors optimized specifically for high performance in ESD applications. They have a non-linear voltage/current characteristic for effectively suppressing extremely fast voltage transients and offer superior parametric stability over the complete operating range of  $-40\text{ }^{\circ}\text{C}$  to  $+85\text{ }^{\circ}\text{C}$ .

CeraDiodes are bi-directional devices. A single CeraDiode connected from signal/data line to ground routes both positive and negative ESD transitions safely to the ground plane. This technique eliminates the need to route ESD charge into the power plane, possibly damaging nearby integrated circuits.

### Features

- Bi-directional ESD protection to IEC 61000-4-2 (level 4)
- Suitable for uni- and bi-directional lines
- Bi-directional ESD protection in a two-pin line
- Routes all ESD events, both positive and negative, safely to ground
- Suitable for DC working voltages up to 22 V
- No derating of maximum ratings up to 85 °C
- Surface mount package in case sizes
  - 0402 (semiconductor package SOD-723)
  - 0603 (semiconductor package SOD-523)
  - 1003 (semiconductor package SOD-323)
- Extremely fast response time  $< 0.5\text{ ns}$
- Lead-free nickel barrier terminations suitable for lead-free soldering
- RoHS-compatible

### Applications

- EDP products (e.g. desktop and notebook computers)
- Peripherals (e.g. printers, memory cards, etc.)
- Portable handheld products (e.g. PDA)
- Mobile communication
- Consumer products (Flat TVs, set top boxes, MP3 players, digital cameras, etc.)
- Liquid crystal displays (LCD) / monitors

## Application example

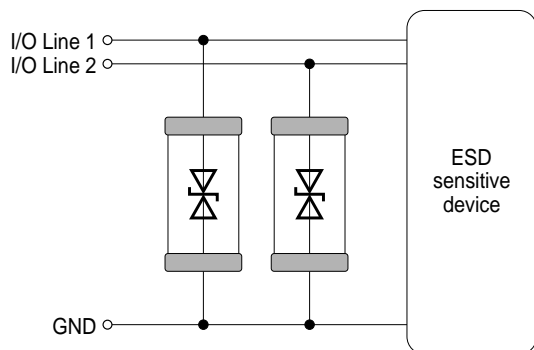

**Note:** Protection of I/O lines with single CeraDiodes.

## Pin configuration

Pin	Description
P1	GND
P2	I/O Line

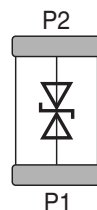

Due to the symmetrical configuration no marking information is needed. P1 and P2 can be interchanged.

## Maximum ratings ( $T_A = 85\text{ °C}$ )

Rating	Symbol	Value	Unit
Maximum DC working voltage	$V_{DC}$	CDS2C05GTA: 5.6 CDS2C15GTA: 15 CDS3C05GTA: 5.6 CDS3C09GTA: 9 CDS3C15GTA: 15 CDS3C20GTA: 22 CDS4C12GTA: 12	V
Peak pulse current @ 8/20 $\mu$ s	$I_{PP}$	CDS2C05GTA: 10 CDS2C15GTA: 10 CDS3C05GTA: 30 CDS3C09GTA: 30 CDS3C15GTA: 30 CDS3C20GTA: 30 CDS4C12GTA: 20	A



Rating	Symbol	Value	Unit
Peak pulse power @ 8/20 $\mu$ s	P <sub>PP</sub>	CDS2C05GTA: 320 CDS2C15GTA: 670 CDS3C05GTA: 1000 CDS3C09GTA: 1600 CDS3C15GTA: 2000 CDS3C20GTA: 2200 CDS4C12GTA: 1000	W
Air discharge ESD capability (to IEC 61000-4-2 method)	V <sub>ESD</sub>	15	kV
Contact discharge ESD capability (to IEC 61000-4-2 method)	V <sub>ESD</sub>	8	kV
Operating temperature (without derating)	T <sub>op</sub>	-40 to +85	°C
Storage temperature	T <sub>stg</sub>	-40 to +125	°C

### Characteristics (T<sub>A</sub> = 25 °C)

#### CDS2C05GTA

Parameter	Symbol	Conditions	Minimum	Typical	Maximum	Unit
Breakdown voltage	V <sub>BR</sub>	I <sub>BR</sub> = 1 mA	6.4	-	-	V
Leakage current	I <sub>leak</sub>	V <sub>leak</sub> = 3.3 V	-	-	1	$\mu$ A
Clamping voltage	V <sub>clamp</sub>	I <sub>PP</sub> = 1 A, 8/20 $\mu$ s	-	-	24	V
Capacitance	C	V = 1 V, f = 1 kHz	-	180	-	pF

#### CDS2C15GTA

Parameter	Symbol	Conditions	Minimum	Typical	Maximum	Unit
Breakdown voltage	V <sub>BR</sub>	I <sub>BR</sub> = 1 mA	20	-	-	V
Leakage current	I <sub>leak</sub>	V <sub>leak</sub> = 5.6 V	-	-	1	$\mu$ A
Clamping voltage	V <sub>clamp</sub>	I <sub>PP</sub> = 1 A, 8/20 $\mu$ s	-	-	46	V
Capacitance	C	V = 1 V, f = 1 MHz	-	47	-	pF

#### CDS3C05GTA

Parameter	Symbol	Conditions	Minimum	Typical	Maximum	Unit
Breakdown voltage	V <sub>BR</sub>	I <sub>BR</sub> = 1 mA	6.4	-	-	V
Leakage current	I <sub>leak</sub>	V <sub>leak</sub> = 3.3 V	-	-	1	$\mu$ A
Clamping voltage	V <sub>clamp</sub>	I <sub>PP</sub> = 1 A, 8/20 $\mu$ s	-	-	19	V
Capacitance	C	V = 1 V, f = 1 kHz	-	470	-	pF

#### CDS3C09GTA

Parameter	Symbol	Conditions	Minimum	Typical	Maximum	Unit
Breakdown voltage	V <sub>BR</sub>	I <sub>BR</sub> = 1 mA	10	-	-	V
Leakage current	I <sub>leak</sub>	V <sub>leak</sub> = 5.6 V	-	-	1	$\mu$ A
Clamping voltage	V <sub>clamp</sub>	I <sub>PP</sub> = 1 A, 8/20 $\mu$ s	-	-	30	V
Capacitance	C	V = 1 V, f = 1 kHz	-	220	-	pF

**CDS3C15GTA**

Parameter	Symbol	Conditions	Minimum	Typical	Maximum	Unit
Breakdown voltage	$V_{BR}$	$I_{BR} = 1 \text{ mA}$	22	-	-	V
Leakage current	$I_{leak}$	$V_{leak} = 5.6 \text{ V}$	-	-	1	$\mu\text{A}$
Clamping voltage	$V_{clamp}$	$I_{PP} = 1 \text{ A}, 8/20 \mu\text{s}$	-	-	42	V
Capacitance	C	$V = 1 \text{ V}, f = 1 \text{ kHz}$	-	160	-	pF

**CDS3C20GTA**

Parameter	Symbol	Conditions	Minimum	Typical	Maximum	Unit
Breakdown voltage	$V_{BR}$	$I_{BR} = 1 \text{ mA}$	25	-	-	V
Leakage current	$I_{leak}$	$V_{leak} = 5.6 \text{ V}$	-	-	1	$\mu\text{A}$
Clamping voltage	$V_{clamp}$	$I_{PP} = 1 \text{ A}, 8/20 \mu\text{s}$	-	-	50	V
Capacitance	C	$V = 1 \text{ V}, f = 1 \text{ MHz}$	-	56	-	pF

**CDS4C12GTA**

Parameter	Symbol	Conditions	Minimum	Typical	Maximum	Unit
Breakdown voltage	$V_{BR}$	$I_{BR} = 1 \text{ mA}$	16	-	-	V
Leakage current	$I_{leak}$	$V_{leak} = 5.6 \text{ V}$	-	-	1	$\mu\text{A}$
Clamping voltage	$V_{clamp}$	$I_{PP} = 1 \text{ A}, 8/20 \mu\text{s}$	-	-	46	V
Capacitance	C	$V = 1 \text{ V}, f = 1 \text{ MHz}$	-	82	-	pF

**Note:** Any operating voltage lower than  $V_{leak}$  results in lower leakage current.

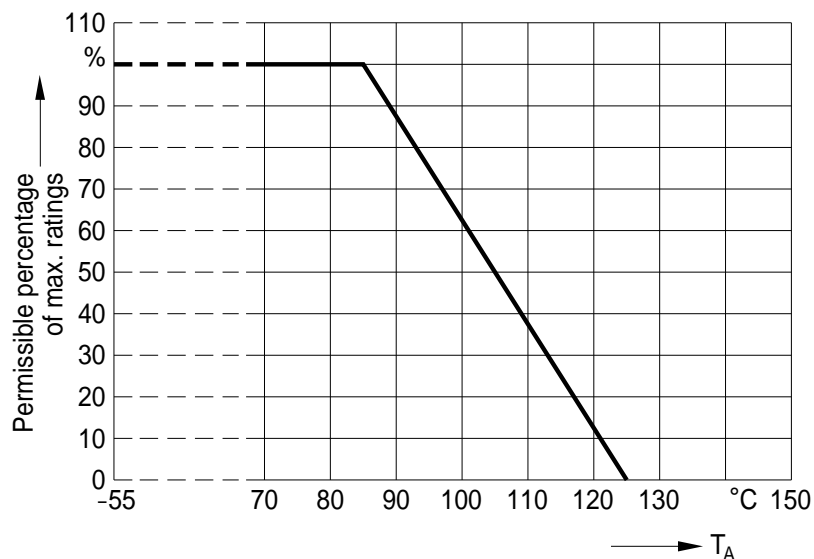
**Typical characteristics**

### Dimensional drawing

Dimensions in mm

Symbol	0402		0603		1003	
	Min.	Max.	Min.	Max.	Min.	Max.
l	0.85	1.15	1.45	1.75	2.34	2.74
w	0.4	0.6	0.7	0.9	0.7	0.9
h	0.4	0.6	0.7	0.9	0.7	0.9
k	0.1	0.3	0.1	0.4	0.13	0.75

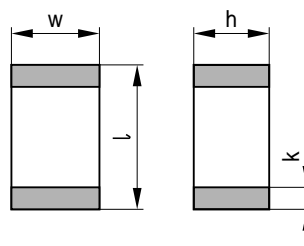

### Recommended solder pad

Dimensions in mm

Symbol	0402	0603	1003
	Dim.	Dim.	Dim.
A	0.6	1.0	0.8
B	0.6	1.0	0.8
C	0.5	1.0	1.45

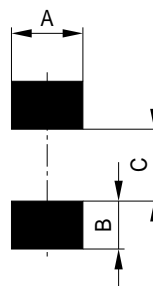

## Recommended infrared reflow soldering temperature profile

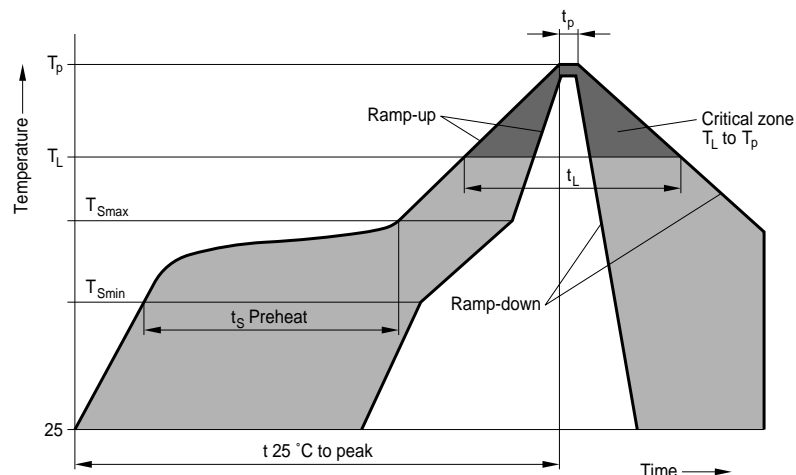

Profile feature	Sn-Pb eutectic assembly	Pb-free assembly
Average ramp-up rate ( $T_{Smax}$ to $T_p$ )	3 °C/ second max.	3 °C/ second max.
Preheat		
- Temperature min ( $T_{Smin}$ )	100 °C	150 °C
- Temperature max ( $T_{Smax}$ )	150 °C	200 °C
- Time ( $t_{Smin}$ to $t_{Smax}$ )	60 ... 120 seconds	60 ... 180 seconds
Time maintained above		
- Temperature min ( $T_L$ )	183 °C	217 °C
- Time ( $t_L$ )	60 ... 150 seconds	60 ... 150 seconds
Peak classification temperature ( $T_p$ )	220 °C ... 240 °C	240 °C ... 260 °C
Time within 5 °C of actual peak temperature ( $t_p$ )	10 ... 30 seconds	20 ... 40 seconds
Ramp-down rate	6 °C/ second max.	6 °C/ second max.
Time 25 °C to peak temperature	6 minutes max.	8 minutes max.

**Note:** All temperatures refer to topside of the package, measured on the package body surface.

## Soldering guidelines

The usage of mild, non-activated fluxes for soldering is recommended, as well as proper cleaning of the PCB.

The components are suitable for reflow soldering to JEDEC J-STD-020C.

## Storage conditions

As far as possible, the components shall be employed within 12 months. They should be left in their original packing to avoid soldering problems due to oxidized contacts.

Storage temperature:  $-25\text{ °C}$  up to  $45\text{ °C}$

Relative humidity:  $< 75\%$  annual average,  $< 95\%$  on max. 30 days in a year.

## Reel dimensions in mm

Definition	Symbol	Dim.	Tolerance
Reel diameter	A	180	$+0/-3$
Reel width (inside)	$W_1$	8.4	$+1.5/-0$
Reel width (outside)	$W_2$	14.4	max.

Package: 8-mm tape

Reel material: Plastic

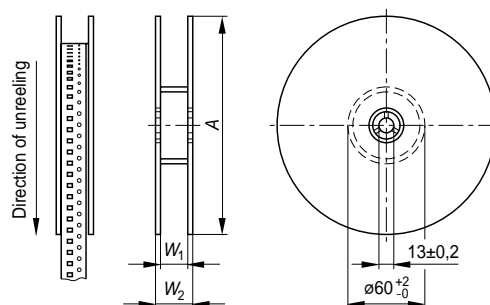

## Selection guide

Part number	Ordering code	Case size	Qty. per reel	Reel size
CDS2C05GTA	B72590D0050A060	0402	10000	180 mm
CDS2C15GTA	B72590D0150A060	0402	10000	180 mm
CDS3C05GTA	B72500D0050A060	0603	4000	180 mm
CDS3C09GTA	B72500D0090A060	0603	4000	180 mm
CDS3C15GTA	B72500D0150A060	0603	4000	180 mm
CDS3C20GTA	B72500D0200A060	0603	4000	180 mm
CDS4C12GTA	B72570D0120A060	1003	4000	180 mm



## Taping to IEC 60286-3

Tape material: Cardboard

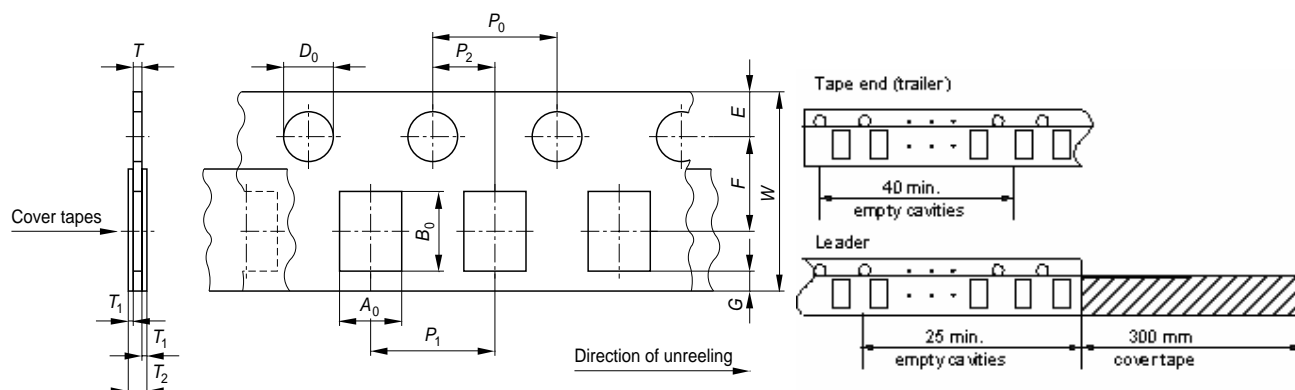

Dimensions and tolerances in mm:

Definition	Symbol	0402 Dim.	0603 Dim.	1003 Dim.	Tolerance
Compartment width	A <sub>0</sub>	0.6	0.95	1.0	± 0.2
Compartment length	B <sub>0</sub>	1.15	1.8	2.85	± 0.2
Sprocket hole diameter	D <sub>0</sub>	1.5	1.5	1.5	+0.1/ -0
Sprocket hole pitch	P <sub>0</sub>	4.0	4.0	4.0	± 0.1 <sup>1)</sup>
Distance centre hole to centre compartment	P <sub>2</sub>	2.0	2.0	2.0	± 0.05
Pitch of the component compartments	P <sub>1</sub>	2.0	4.0	4.0	± 0.1
Tape width	W	8.0	8.0	8.0	± 0.3
Distance edge to centre of hole	E	1.75	1.75	1.75	± 0.1
Distance centre hole to centre compartment	F	3.5	3.5	3.5	± 0.05
Distance compartment to edge	G	0.75	0.75	0.75	min.
Thickness tape	T	0.6	0.9	1.0	max.
Overall thickness	T <sub>2</sub>	0.7	1.1	1.1	max.

1)  $\leq \pm 0.2$  mm over any 10 pitches

## Note

CeraDiodes are not suitable for switching applications or for voltage stabilization, where static power dissipation is required.

## Important notes

The following applies to all products named in this publication:

1. Some parts of this publication contain **statements about the suitability of our products for certain areas of application**. These statements are based on our knowledge of typical requirements that are often placed on our products in the areas of application concerned. We nevertheless expressly point out **that such statements cannot be regarded as binding statements about the suitability of our products for a particular customer application**. As a rule, EPCOS is either unfamiliar with individual customer applications or less familiar with them than the customers themselves. For these reasons, it is always ultimately incumbent on the customer to check and decide whether an EPCOS product with the properties described in the product specification is suitable for use in a particular customer application.
2. We also point out that **in individual cases, a malfunction of passive electronic components or failure before the end of their usual service life cannot be completely ruled out in the current state of the art, even if they are operated as specified**. In customer applications requiring a very high level of operational safety and especially in customer applications in which the malfunction or failure of a passive electronic component could endanger human life or health (e.g. in accident prevention or life-saving systems), it must therefore be ensured by means of suitable design of the customer application or other action taken by the customer (e.g. installation of protective circuitry or redundancy) that no injury or damage is sustained by third parties in the event of malfunction or failure of a passive electronic component.
3. **The warnings, cautions and product-specific notes must be observed.**
4. In order to satisfy certain technical requirements, **some of the products described in this publication may contain substances subject to restrictions in certain jurisdictions (e.g. because they are classed as “hazardous”)**. Useful information on this will be found in our Material Data Sheets on the Internet ([www.epcos.com/material](http://www.epcos.com/material)). Should you have any more detailed questions, please contact our sales offices.
5. We constantly strive to improve our products. Consequently, **the products described in this publication may change from time to time**. The same is true of the corresponding product specifications. Please check therefore to what extent product descriptions and specifications contained in this publication are still applicable before or when you place an order.  
  
We also **reserve the right to discontinue production and delivery of products**. Consequently, we cannot guarantee that all products named in this publication will always be available.
6. Unless otherwise agreed in individual contracts, **all orders are subject to the current version of the “General Terms of Delivery for Products and Services in the Electrical Industry” published by the German Electrical and Electronics Industry Association (ZVEI)**.
7. The trade names EPCOS, EPCOS-JONES, BAOKE, Alu-X, CeraDiode, CSSP, MLSC, PhaseCap, PhaseMod, SIFERRIT, SIFI, SIKOREL, SilverCap, SIMID, SIOV, SIP5D, SIP5K, UltraCap, WindCap are **trademarks registered or pending** in Europe and in other countries. Further information will be found on the Internet at [www.epcos.com/trademarks](http://www.epcos.com/trademarks).