

ENERGIZER EN715

7.5V



Specifications

NOT INTENDED FOR RETAIL TRADE

Classification:	Alkaline
Chemical System:	Zinc-Manganese Dioxide (Zn/MnO ₂) No added mercury or cadmium
Nominal Voltage:	7.5 volts
Operating Temp:	-18°C to 55°C (0°F to 130°F)
Typical Weight:	2300 grams (81.4 oz.)
Typical Volume:	1570 cubic centimeters (95.8 cubic inch)
Jacket:	Metal
Cells:	Ten 3-361 Two parallel strings of five in series
Terminal:	Screw Post

Simulated Application Tests (21°C)

TYPICAL DISCHARGE
8 ohm continuous

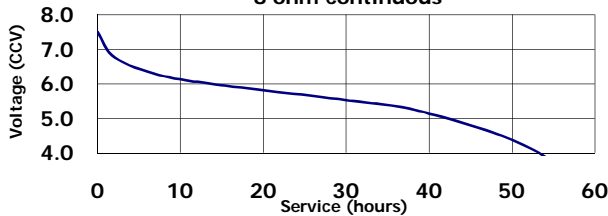

TYPICAL DISCHARGE
2.46 ohm continuous

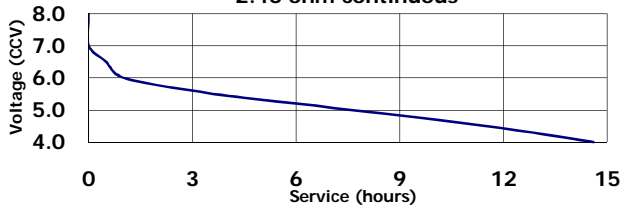

Milliamp-Hours Capacity

Continuous discharge to 3.0 volts at 21°C

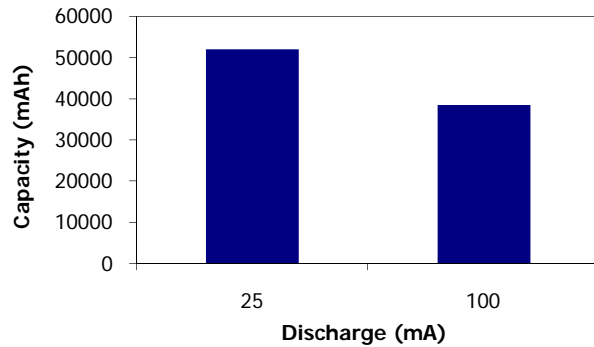

Industry Standard Dimensions

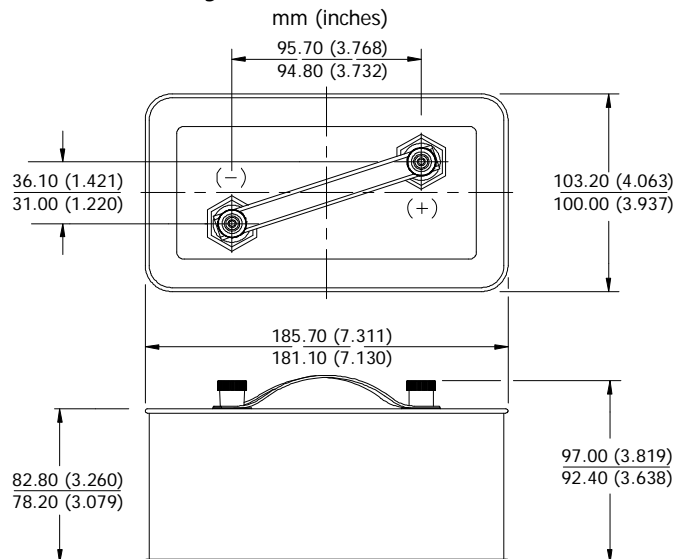

Important Notice

This datasheet contains typical information specific to products manufactured at the time of its publication.
©Energizer Holdings, Inc. - Contents herein do not constitute a warranty.