

**Alkaline-Manganese Dioxide Battery**

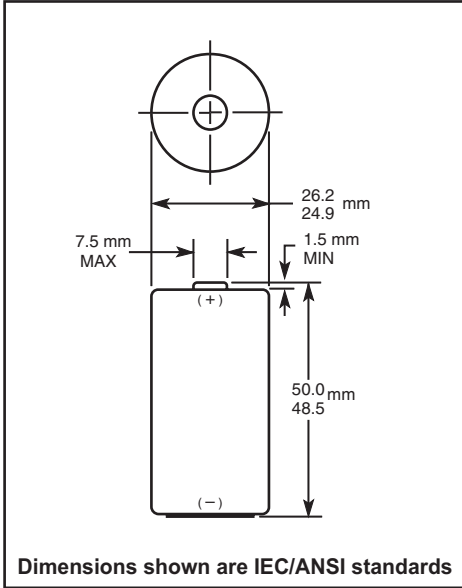

<b>Nominal Voltage:</b>	1.5 V
<b>Operating Voltage</b>	1.6 - 0.75V
<b>Impedance:</b>	150 m-ohm @ 1kHz
<b>Typical Weight:</b>	69 gm (2.4 oz.)
<b>Typical Volume:</b>	26.9 cm <sup>3</sup> (1.6 in. <sup>3</sup> )
<b>Terminals:</b>	Flat
<b>Storage Temperature Range:</b>	-20 °C to 35 °C
<b>Operating Temperature Range:</b>	-20 °C to 54 °C (-4 °F to 130 °F)
<b>ANSI:</b>	14A
<b>IEC:</b>	LR14



TYPICAL DISCHARGE CHARACTERISTICS AT 21 °C (70 ° F)

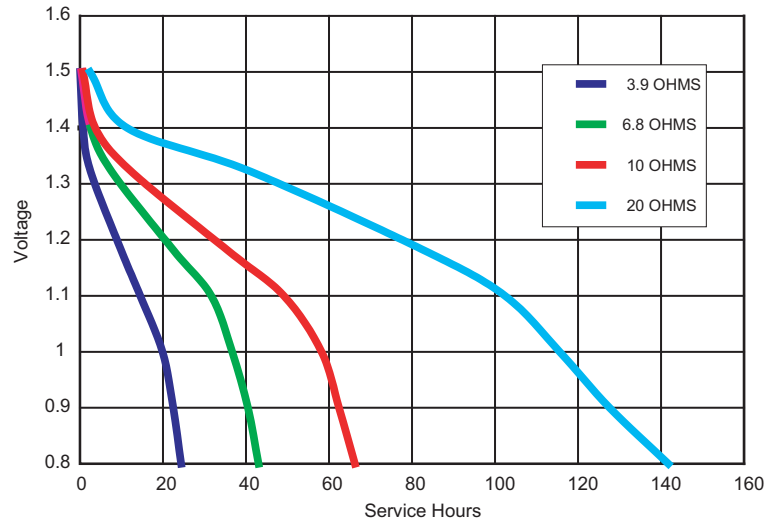

**DURACELL®**  
 BATTERIES

Berkshire Corporate Park  
 Bethel, CT 06801 U.S.A.  
 Telephone: Toll-free 1-800-544-5454  
 Internet: www.duracell.com

\* Delivered capacity is dependent on the applied load, operating temperature and cut-off voltage. Please refer to the charts and discharge data shown for examples of the energy / service life that the battery will provide for various load conditions.

TYPICAL DISCHARGE CHARACTERISTICS  
 AT 21°C (70°F)

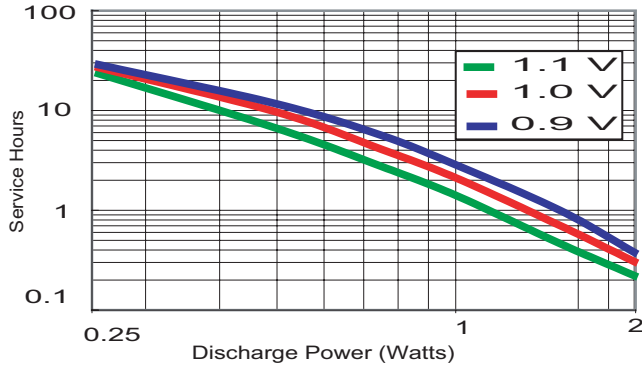

TYPICAL DISCHARGE CHARACTERISTICS  
 AT 21°C (70°F)

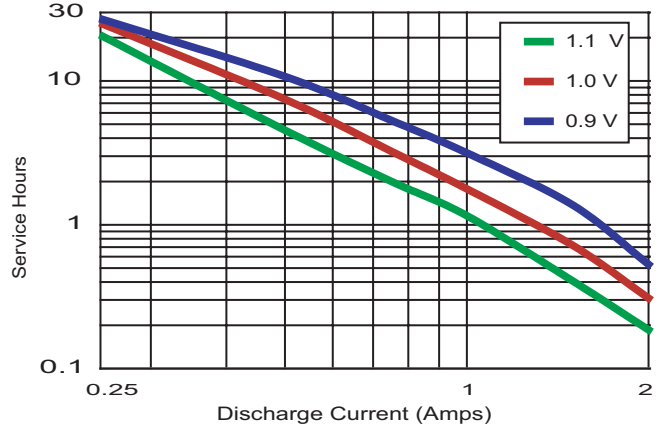

TYPICAL DISCHARGE CHARACTERISTICS  
 AT 21°C (70°F)

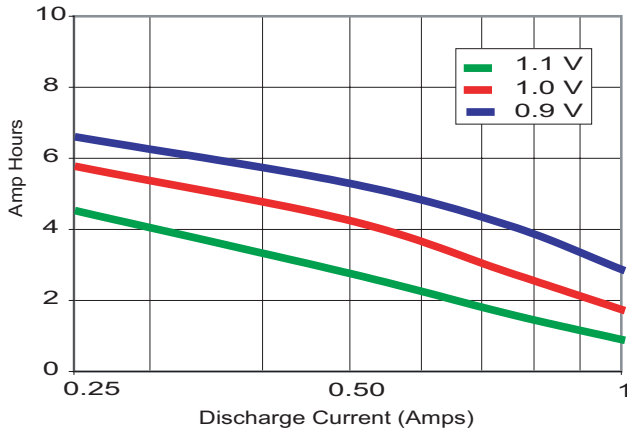

TYPICAL DISCHARGE CHARACTERISTICS  
 AT 21°C (70°F)

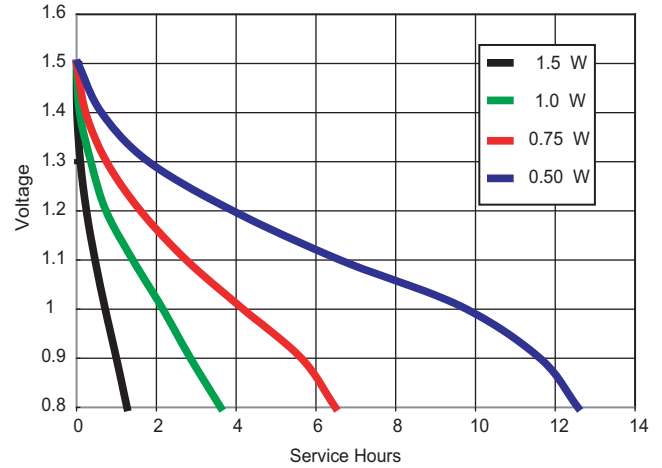

TYPICAL FLASHLIGHT TEST  
 AT 21°C AND 0°C

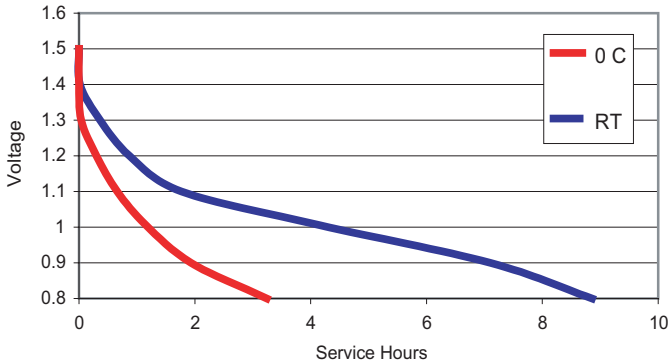

**DURACELL®**  
 BATTERIES

Berkshire Corporate Park  
 Bethel, CT 06801 U.S.A.  
 Telephone: Toll-free 1-800-544-5454  
 Internet: [www.duracell.com](http://www.duracell.com)

\* Delivered capacity is dependent on the applied load, operating temperature and cut-off voltage. Please refer to the charts and discharge data shown for examples of the energy / service life that the battery will provide for various load conditions.