

Part Number: **5913001102F**

### General Description

Series	591
Configuration	3 mm Lens
Description	3MM SQ PRISM R/G SAMPLE STRI
Package Options	Sample Strip
Sizes	3mm
Lamp Type	Bi-Color

### Operating Characteristics

Color	Bi-Color (R & G)
-------	------------------

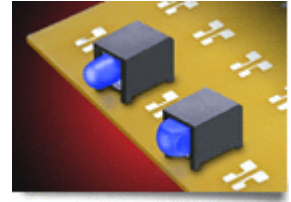

This is a  
RoHS Compliant Product  
To learn more click here

REV.	ECN NO.	REVISIONS	DRN.	CKD.	APP.	DATE
A		NEW RELEASE	TWC			

BI-COLOR OPERATING CHARACTERISTICS AT T <sub>a</sub> = 25 °C AMBIENT																					
DIALIGHT P/N	COLOR	I <sub>f</sub> (mA)	FORWARD VOLTAGE (V)		LUMINOUS INTENSITY (mcd)		REVERSE CURRENT (μA)		PEAK WAVELENGTH (nm)		DOMINANT WAVELENGTH (nm)		REVISIONS								
			TYP.	MAX.	MIN.	TYP.	MAX.	TYP.	MAX.	TYP.	MIN.	TYP.	MAX.	REV.	ECN.	DRN.	DATE				
591-3001-102F	RED GREEN	10	2.0	2.5	4.5	11.3	18.0	.01	10	635	572	622	570	628	576	634	576	A		TWC	8-8-05
591-3001-107F	RED GREEN	10	2.0	2.5	4.5	11.3	18.0	.01	10	635	572	622	564	628	570	634	576	A		TWC	8-8-05
591-3001-113F	RED GREEN	10	2.0	2.5	4.5	11.3	18.0	.01	10	635	572	622	564	628	570	634	576	A		TWC	8-8-05

ABSOLUTE MAXIMUM RATING AT 25°C AMBIENT	591-3001-1XXF			UNITS
	102F RED GREEN	107F RED GREEN	113F RED GREEN	
POWER CONSUMPTION	95			mW
CONTINUOUS FORWARD CURRENT	30			mA
REVERSE VOLTAGE	5			V
OPERATING TEMPERATURE	-40 TO +100			°C
STORAGE TEMPERATURE				

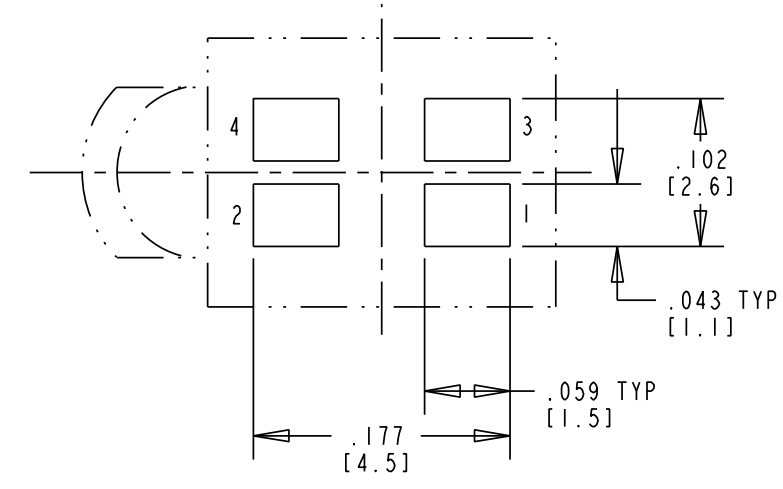

COMPONENT SIDE  
RECOMMENDED PC BOARD LAND PATTERN  
(DIM'S ± .004)

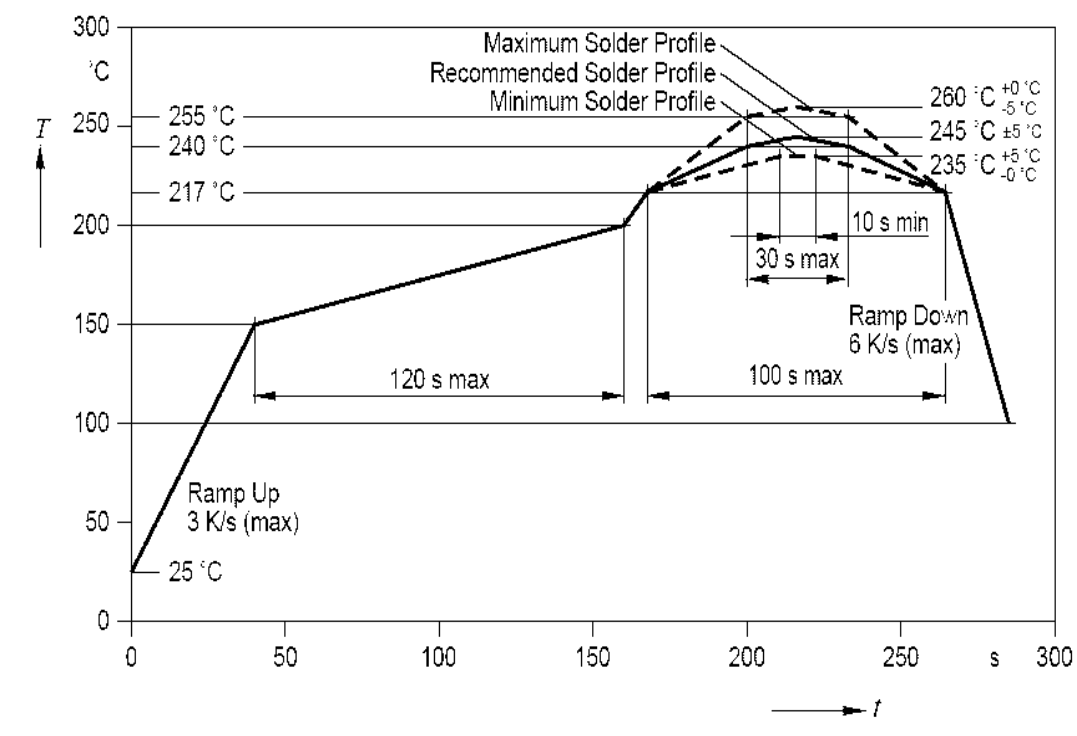

NOTES:

- MILLIMETER DIMENSIONS SHOWN FOR REFERENCE ONLY.
- PAD NUMBERS FOR REFERENCE ONLY. DESIGNATION NON-EXISTENT ON PART.
- STORAGE CONDITIONS FOR TAPED PRODUCT: RE-TAPING MAY BE NECESSARY FOR PRODUCT STORED MORE THAN TWELVE MONTHS.
- LEADS: TIN (Sn) OVER NICKEL (Ni) ON COPPER ALLOY (Cu)
- ORDER QUANTITY IS LED ASSEMBLIES. NOT REELS.
- 102F SUFFIX MEANS PARTS ARE PACKED ON A 20 PCS SAMPLE STRIP.  
-107F SUFFIX MEANS PARTS ARE PACKED ON 7 INCH REEL, 400 PCS/REEL.  
-113F SUFFIX MEANS PARTS ARE PACKED ON A 13 INCH REEL, 1600 PCS/REEL.
- LENS MOVEMENT IN RELATIONSHIP TO THE HOUSING IS:  
.009" T.I.R. VERTICALLY.  
.007" T.I.R. HORIZONTALLY.
- FRONT AND REAR TERMINALS OF ASSEMBLY TO BE WITHIN .005 COPLANARITY.
- DIALIGHT PART NUMBER: 591-3001-102F, 591-3001-107F, 591-3001-113F.
- DEVICE HAS A MOISTURE SENSITIVITY LEVEL "2" CAUTION LABEL APPLIED AS PER JEDEC STD. 033.
- THIS PRODUCT IS RoHS COMPLIANT (Pb FREE). EACH BAG AND REEL IS MARKED WITH THE RoHS COMPLIANT LABEL P/N 9100-117-0852-99 OR EQUIVALENT MARKINGS.

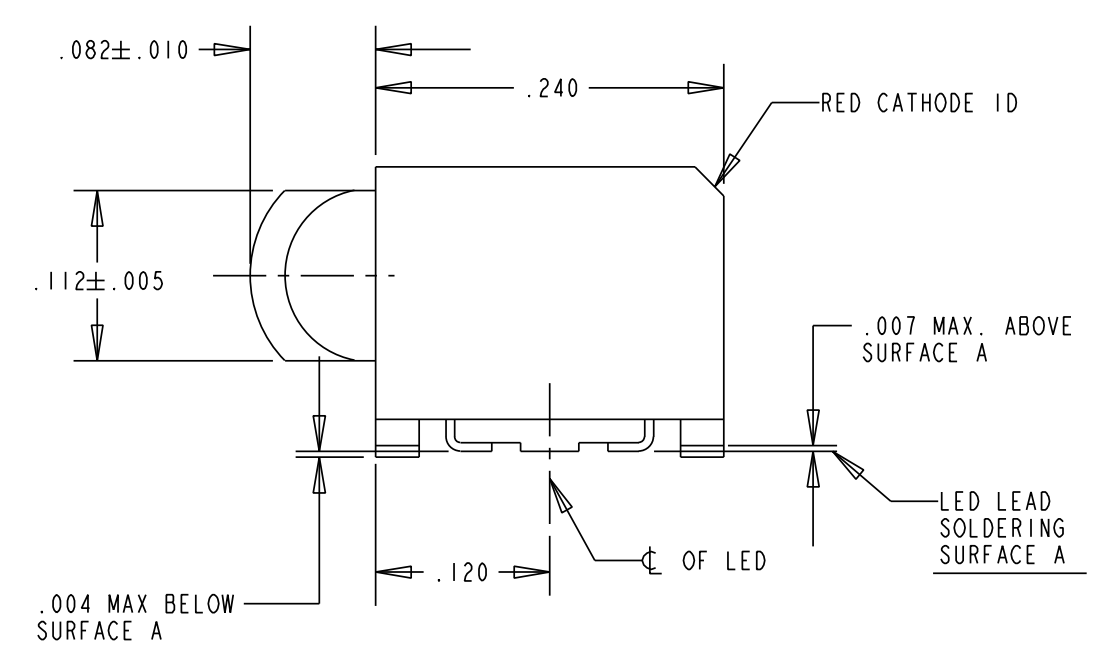
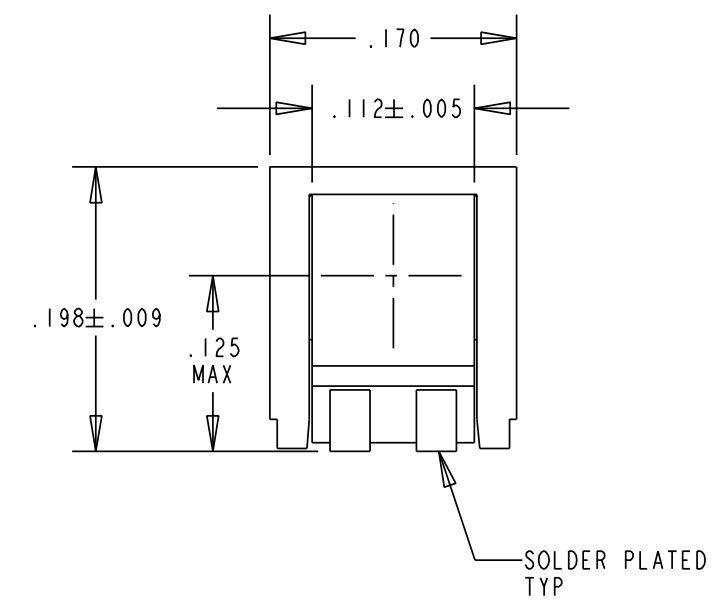

TAPING SPECIFICATION

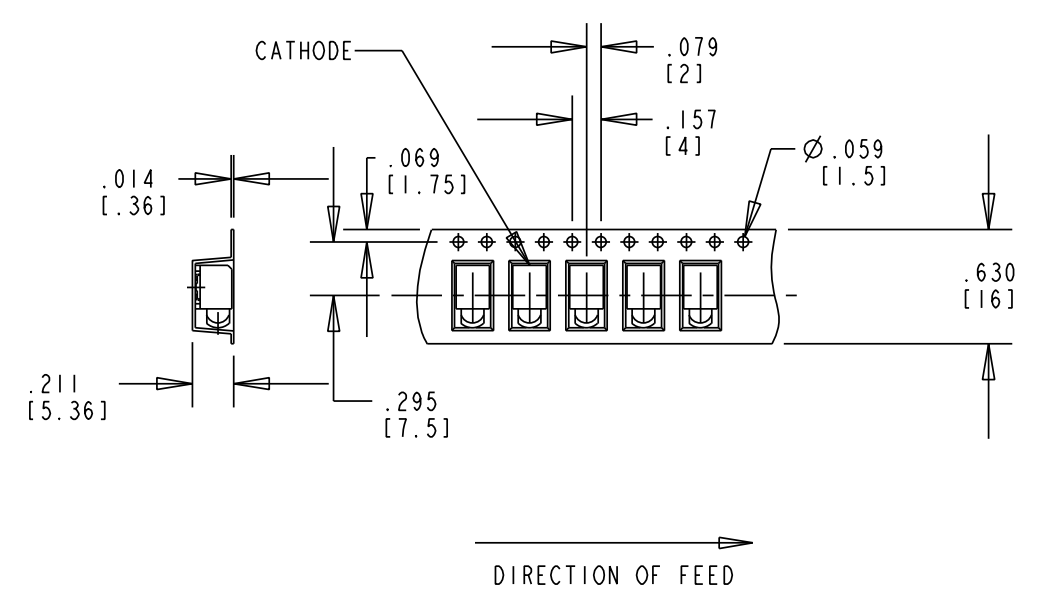

TOLERANCE: .004 UNLESS OTHERWISE SPECIFIED.  
MILLIMETER DIMENSIONS SHOWN FOR REFERENCE ONLY.

REEL SPECIFICATION

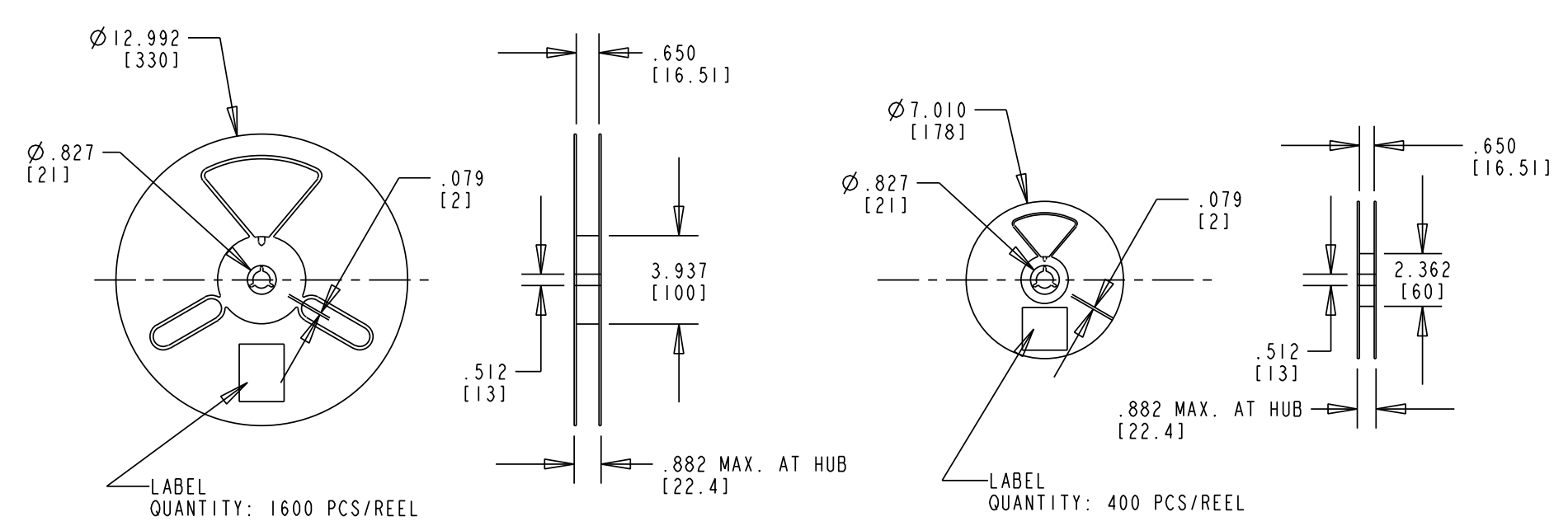

13 INCH DIA. REEL SPECIFICATIONS

7 INCH DIA. REEL SPECIFICATIONS

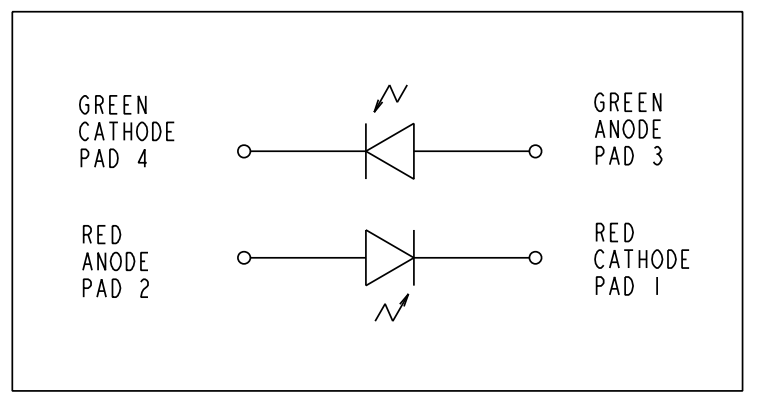

SCALE: DRAWING SCALE	DRAWING NUMBER	REV
ALL DIM'S IN: INCHES (MM)	C-17282	A
TOLERANCES: UNLESS OTHERWISE SPECIFIED	TITLE 3mm PRISM SURFACE MOUNT CBI RoHS COMPLIANT	
FRACTIONS: ±1/64	MATERIAL	
DECIMALS (.XX): ±.01	FINISH:	
DECIMALS (.XXX): ±.005	Dialight	
DECIMALS (.XXXX): ±.0005	FSCM 83330	
ANGLES: ±1°	SHEET 1 OF 1 FAMILY TABLE:	