

Micro Meg™ Pocket Megohmmeter Operation and Maintenance



Made in America



Figure 1. 19635 Micro Meg Pocket Megohmmeter

Description

The Desco 19635 Micro Meg Pocket Megohmmeter is a portable test instrument designed for measuring both surface and surface-to-ground resistance of static dissipative and conductive materials. Seven color-coded LEDs, read from right to left, easily identify static dissipative and conductive ranges. The μMeg will test materials with surface resistivity of 1×10^5 to 1×10^{10} . This test instrument is ideally suited for Quality Control and Field Service personnel as well as for use in routine auditing of your ESD protective materials. The μMeg features simple one-button operation and a 9V battery for ease of use and maximum portability. This auto-ranging instrument weighs only six ounces. The high-impact plastic case ensures durability despite the meter's light weight.

The Micro Meg has not been designed to meet ESD S4.1 test equipment requirements and therefore measurements obtained with this device may not agree with measurements taken according to the ESD S4.1 test procedure. This test instrument is intended for use only as an auxiliary tool for monitoring surface resistance performance.

If you are interested in obtaining a meter which does meet all the test equipment requirements of ESD S4.1, we recommend our model 19780 Surface Resistance Test Kit. For more information on this product ask for Technical Bulletin TB-3014.

Installation

Remove the meter from the carton and inspect for damage. Each unit should be fully charged and includes:

- 1 Micro Meg Pocket Megohmmeter
- 1 Surface-to-Ground, cord assembly
- 1 Installed 9V battery

Properly store the megohmmeter and its component assemblies when not in use.

Operation

The Micro Meg will perform Surface Resistivity and Surface-to-Ground resistance measurements. Work surfaces and materials to be tested should be cleaned prior to testing to ensure that surface dirt and contamination do not affect results. It is recommended that non-silicone and non-alcohol based cleaners such as Desco's Reztore™ Surface and Mat Cleaner be used for regular cleaning of ESD protective work surfaces. When non-ESD surfaces are being used, Reztore™ Topical Antistat is recommended for eliminating static charge generation.

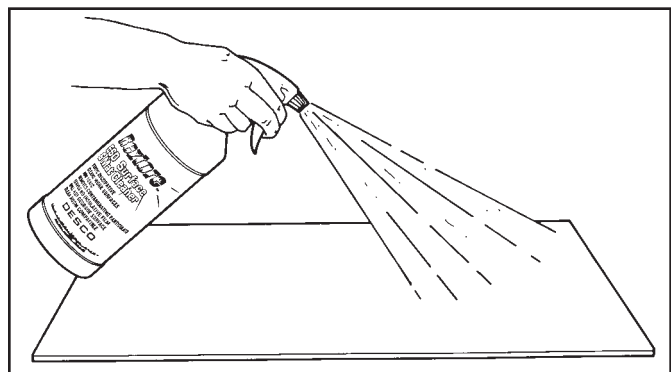

Figure 2. Cleaning the work surface before testing.

Surface and Surface-to-Ground resistance readings are indicated by the series of LEDs on the face of the meter. The LEDs are read from right to left as follows:

- | | | |
|-----------|---|--|
| 1. RED | – | >10E10, Meter is on and battery is functioning |
| 2. GREEN | – | Less than 1×10^{10} |
| 3. GREEN | – | Less than 1×10^9 |
| 4. GREEN | – | Less than 1×10^8 |
| 5. GREEN | – | Less than 1×10^7 |
| 6. YELLOW | – | Less than 1×10^6 |
| 7. YELLOW | – | Less than 1×10^5 |

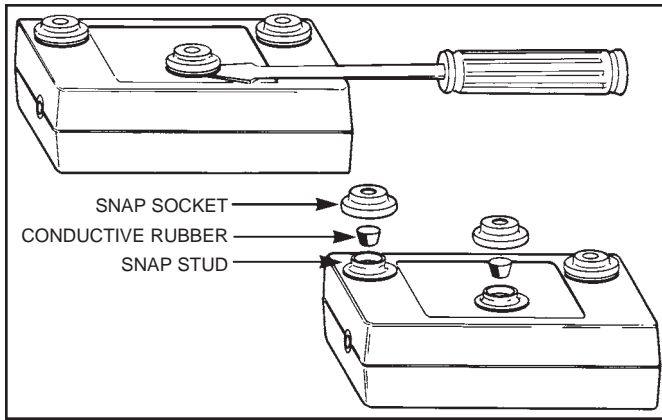

Figure 6. Cleaning the electrodes.

2. Clean both the snap stud and the electrodes with a cotton swab soaked in isopropyl alcohol. Check the rubber centers for wear - the rubber should form a convex spot on the bottom of the electrode. The three electrodes will be checked with each annual, factory calibration. If electrode replacement is recommended, the customer will be notified with estimated charges before any changes are made.

Theory of Operation

The Micro Meg measures resistance by setting up a bridge between two precision 1% resistors of known value and the surface tested, of unknown value. When the white button is depressed a test voltage of 9 VDC is applied to the megohmmeter's center electrode or ground cord, depending on the test being performed. One of the bottom electrodes on the outside of the meter supplies the resistance bridge. The test voltage resulting from the bridge is compared to reference voltages established by six trimming potentiometers. Two integrated circuits are configured as comparators to check the voltage from the bridge against the potentiometers. Based on the setting of each potentiometer, the appropriate LED is lit.

Specifications

Sensitivity Range

Surface Resistivity Less than $10E10$ ohms/sq
 Surface-to-Ground Less than $10E9$ ohms

LED Key (from right to left)

1. Red $>10E10$, Meter On, and Battery OK
2. Green $<10E10$ Static Dissipative
3. Green $<10E9$ Static Dissipative
4. Green $<10E8$ Static Dissipative
5. Green $<10E7$ Static Dissipative
6. Yellow $<10E6$
7. Yellow $>10E5$ Conductive

Test Sample Size 3" x 1-1/2" or larger

General Characteristics

Power Supply 9 volt alkaline battery (included)
Test Voltage Nominal 9 volts
Electrodes Steel and conductive rubber

Temperature Range

Operating 40°F to 120°F (10°C to 40°C)
 Storage 42°F to 110°F (-15°C to +60°C)

Relative Humidity

0% to 99% (non condensing)

Operation

Resistance bridge

Readout

Seven LEDs

Resolution

One order of magnitude

Accuracy

$\pm 10\%$ all, except $\pm 20\%$ 10^9 , 10^{10}

Repeatability

$\pm 3\%$

Weight

6 ounces

Dimensions

4" x 2.5" x 1.75"

Calibration

Equipment Required:

- 1% resistors of the following values: 100K, 1M, 10M, 100M, 1G, 10G ohms

Your Micro Meg Pocket Megohmmeter will ordinarily remain calibrated. It is however important to verify calibration regularly. This may be done at the factory or you may do it yourself.

Remember, unauthorized servicing or modifications to the Micro Meg will void the product warranty. Servicing should only be preformed by the factory.

Verification of Calibration:

Place the Micro Meg on an insulator (e.g. Teflon or glass) and press the white test button. Only the first red LED on the right, marked "ON" should be illuminated. If this LED fails to light, the battery should be replaced before proceeding.

Place a 10G ohm resistor across the middle electrode and the side electrode. Do not use the side electrode that is installed on the battery cover for this test. Press the test button. The second LED should light. Be sure not to contact the leads or the electrodes as your body's resistance will effect the readings. Continue the process with each consecutive resistor, checking to make sure the appropriate LEDs are illuminated. If all resistors check properly, the unit's calibration is verified.