

- A. Dual banana jacks for grounding two wrist straps (.162" - .164" ± .002" ID).
- B. Black anodized aluminum angle bracket frame, mounts underneath worksurface.
- C. Dual .155" (4mm) studs for "parking" wrist strap ground cords when not in use.
- D. 10' ground wire. Insulator: PVC, yellow striped green, .100" OD. Conductor: 105 strands each. Approximately 22 gauge with a #10 (.200" ID) ring terminal.
- E. Slotted bracket allows easy installation for screws with a maximum diameter of .175" (4.4mm).
- F. Grounding symbol markings on each banana jack.
- G. Extra #10 (.200" ID) ring terminal for custom installation.
- H. Vinyl boot insulates electrical circuits.

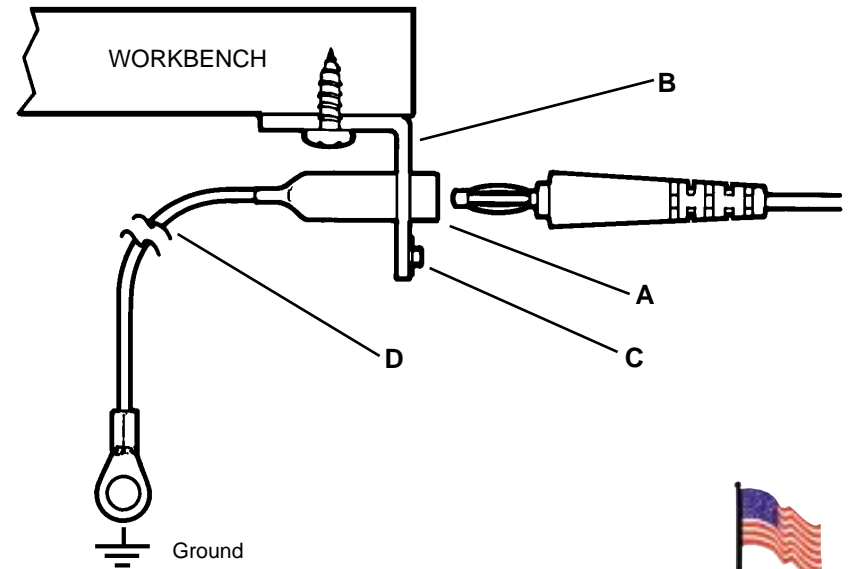
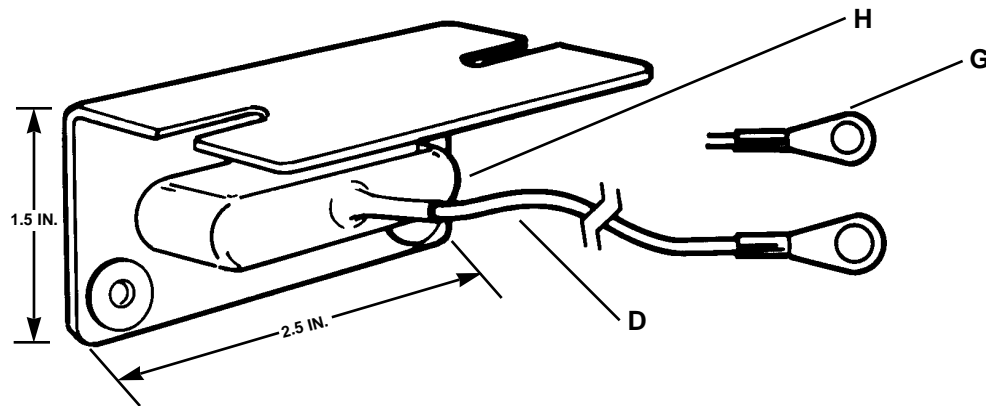
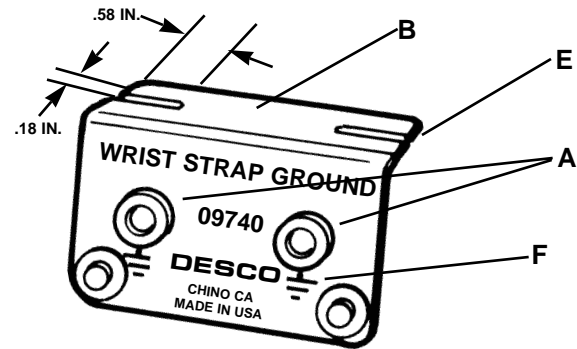

Made in America

GROUND CORD, DUAL WRIST STRAP, BENCH MOUNT

DESCO

DESCO WEST: 3651 WALNUT AVE., CHINO, CA 91710 WEB SITE: www.desco.com
 PHONE (909) 627-8178 FAX (909) 627-7449 FAX REQUEST (909) 627-7126
 DESCO EAST: 90 HUDSON RD, CANTON, MA 02021-1407
 PHONE (781) 821-8370 FAX (781) 575-0172

DRAWING NUMBER
09740

DATE:
9/01