

# JR SERIES ALTERNATING RELAY

UL listed CSA recognized

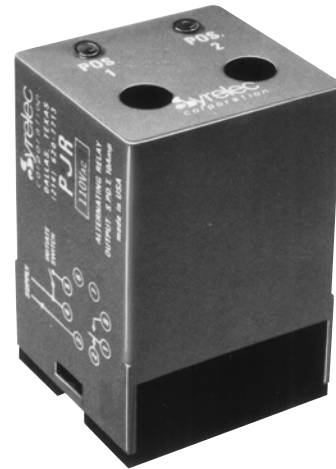

- Duplex Alternating Control
- SPDT or DPDT Control Relay
- 10 Amp Rated
- Externally Controlled

The electronic alternating relay is designed to replace mechanical style devices used in control applications requiring a duplexing or alternating action of the control circuits to operate pumps, compressors, etc. This is achieved by activating a control switch which is common to one side of the input control voltage. The output contact of the relay(s) change state when this switch is opened

(on de-energization of the control circuit). When the control initiate switch is actuated and released or opened, the relay will change state. The next time the initiate switch is actuated and released it will change back to its original state. Two red LED's located on the top of the dust resistant enclosure provide the status of the relay.

5

### SPECIFICATIONS:

<b>Input</b> .....	24 VAC/DC, 110, 220 VAC ± 15%, 50/60 Hz
<b>Maximum power consumption</b> ...	24 VAC: 1.5 VA 110 VAC: 5 VA 220 VAC: 11 VA
<b>Output</b> .....	SPDT 10 A resistive DPDT 10 A resistive DPDT 10 A crosswired
<b>Minimum pulse</b> .....	30 ms
<b>Contact material</b> .....	AgCdO
<b>Maximum loading</b> .....	10 A AC resistive 8 A DC inductive
<b>Maximum switching voltage</b> .....	250 VAC 250 VDC
<b>Relay maximum power rating</b> .....	2200 VA 80 W
<b>Mechanical life of relay</b> .....	3 x 10 <sup>6</sup> operations
<b>Electrical life of relay</b> .....	2 x 10 <sup>5</sup> at 2200 VA resistive load
<b>Operating temperature</b> .....	14°F to 140°F -10°C to +60°C
<b>Weight</b> .....	2.8 oz. (100g)

### WIRING DIAGRAM:

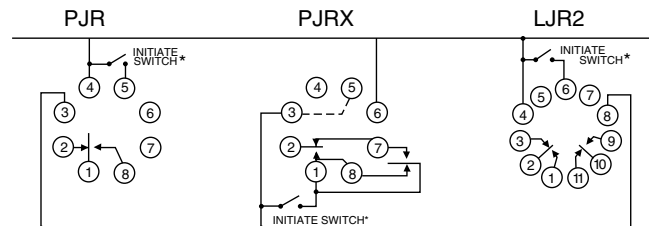

\* INITIATE SWITCH must be isolated from other circuits

### ORDERING INFORMATION:

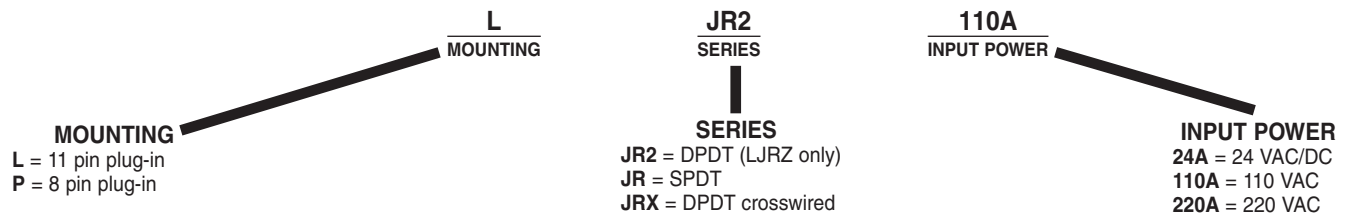

DIMENSIONS:

D - DIN-Rail

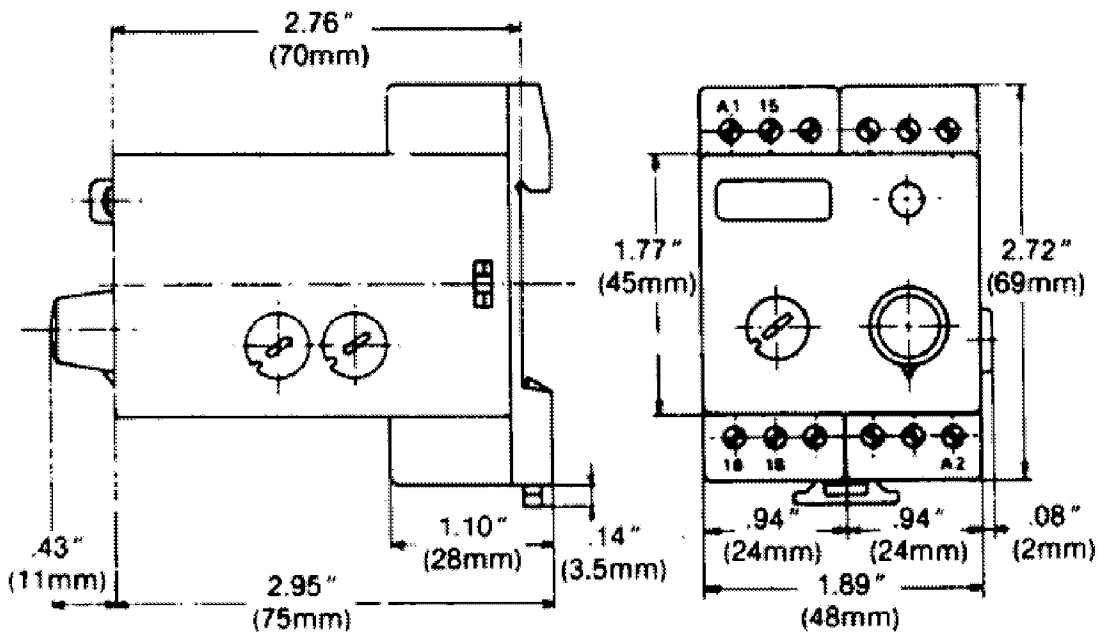

L & P - Sockets

