

Crouzet GNR Series 90mm DIN Rail Solid State Relays

[Crouzet Products /Automation Controls /Solid State Relays /GNR Series Din Rail Solid State Relays /GNR Series 90mm DIN Rail Solid State Relays](#)

PRODUCT FEATURES

- ✚ Integral heat sink eliminates the need for complex thermal calculations
- ✚ DBC substrate for superior thermal performance
- ✚ Epoxy-free design minimizes internal component stress
- ✚ Standard ratings 25 amps at 600Vac
- ✚ No external transient protection required (internal TVS)
- ✚ LED indicator clearly identifies the relay's input status
- ✚ IP20 touch-safe housing
- ✚ AC or DC inputs
- ✚ 4000Vac Optical Isolation
- ✚ UL Recognized, CSA Approved, TUV Approved, CE Certified
- ✚ EMC Compliant for reliable operation in harsh environments
- ✚ Contactor Configuration

[3D CAD File - 90mm Solid State Relay](#)

[Installation Instructions - PDF](#)



90MM Three-Phase SCR Output

Current	Output Voltage	Input Voltage	Terminal Configuration	Switching	Part number	
25 A	48-600 V AC	180-280 V AC	Contactors	Zero Voltage	GNR25ACZ	Check Stock
25 A	48-600 V AC	90-140 V AC	Contactors	Zero Voltage	GNR25BCZ	Check Stock
25 A	48-600 V AC	4-32 V DC	Contactors	Zero Voltage	GNR25DCZ	Check Stock
25 A	48-600 V AC	4-32 V DC	Contactors	Instantaneous	GNR25DCR	Check Stock

90mm THREE-PHASE DIN-RAIL SSR



- ▶ Epoxy-Free Design Minimizes Internal Component Stress
- ▶ DIN-RAIL or Panel Mount
- ▶ Contactor Output Terminal Configuration
- ▶ DBC Substrate for Superior Thermal Performance
- ▶ 100k-cycle UL508 Endurance Rating for Enhanced Reliability
- ▶ Back-to-Back Dual SCR Output
- ▶ No External Transient Protection Required (Internal TVS)
- ▶ Zero-Crossing or Random-Fire Output
- ▶ UL / CSA / TUV Approved, CE Compliant
- ▶ EMC Compliant for Reliable Operation in Harsh Environments



Output Specifications

Voltage range (Vrms)	48-600Vac
Output Current	25
Peak Voltage (Vpk, t = 1 min.)	1100
Off-state leakage uArms	250
(@ max. line voltage & Ta = 25°C)	
Minimum Current (mArms)	100
Max. 1 cycle surge current	500
(Apk, Ta = 25°C)	
Max. 1 second surge current	100
(Apk, Ta = 25°C)	
Forward voltage drop	1.35
(Vpk @ Imax, Ta = 25°C)	
I ² T (60Hz, ½ cycle)	1040
Static off-state dv/dt	500
(Vµs, Ta = 25°C)	
HP Ratings at 480V	3
Output Type	SCR
Min/Max stranded wire	16/8 AWG
Min/Max solid wire	16/10 AWG

Input Specifications

Input voltage	4-32Vdc	90-140VAC	180-280VAC
Drop out voltage	1Vdc	10VAC	10VAC
Min. input current (for on-state)	50mA	15mA	19mA
Maximum input current	62mA	19mA	24mA
Input Resistance (Ohms)	Current Regulated		
Turn-on time*	8.33msec	20mSec	20mSec
Turn-off time	8.33msec	30mSec	30mSec
Min/Max stranded/solid wire	24/16 AWG		

* Random SSR's turn on in less than 100µs

General Characteristics

Operating Temperature (°C)**	-20° to + 80°
Storage Temperature (°C)	-40° to + 100°
Input to output isolation	4000Vrms
Input/output to ground isolation	2500Vrms
Input to output capacitance	8pF (typical)
Operating Frequency	47 to 63 Hz
Housing Material	UL 94V0 (self extinguishing)
Weight (gr)	600

** -20 to +60 for 180-280VAC input

Standards of Compliance

CE Compliant with the LVD 73/23/EEC	
UL Recognized per UL 508 and CSA C22.2 no. 14-95	
TUV Certified per EN 60950	
IEC 62314	
IEC 60068-2-6	35mm/10-55Hz
IEC 60068-2-27	15G / 11ms
IEC 61000-4-2 Level 3	Electrostatic Discharge
IEC 61000-4-3 Level 3	Radiated Electromagnetic Noise
IEC 61000-4-4 Level 3	Immunity to Electrically Fast Transients
IEC 61000-4-5 Level 3	Immunity to Electrical Surges
IEC 61000-4-6 Level 3	Conducted Electromagnetic Noise
CISPR 11 Class A	Conducted and Radiated Noise for Industrial Environments
Pollution Degree 2	

Part Numbers

Zero Crossing Output			
Rating	Output	Input	Part Number
25 Amp	48-600Vac	180-280VAC	GNR25ACZ
25 Amp	48-600Vac	90-140VAC	GNR25BCZ
25 Amp	48-600Vac	4-32Vdc	GNR25DCZ
Random Fire Output			
Rating	Output	Input	Part Number
25 Amp	48-600Vac	4-32Vdc	GNR25DCR

AC Input Equivalent Circuit

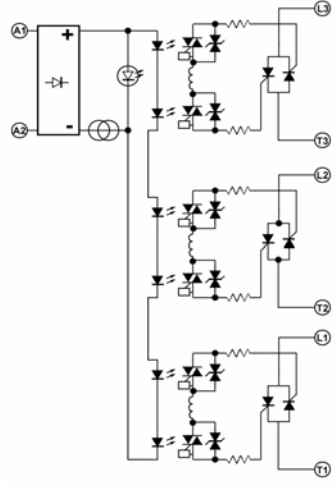

DC Input Equivalent Circuit

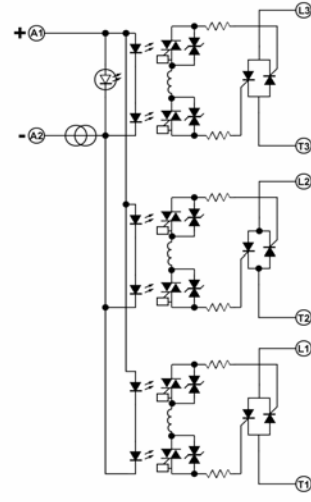

AC Input Equivalent Circuit

DIN-Rail SSR Dimensional Drawings



Dimensions mm (inches)

