

FIREWIRE

IEEE 1394

IEEE 1394 FIREWIRE

DESCRIPTION

Amphenol introduces a new state-of-the-art design in the next generation of high performance communication interfaces for the future. The FireWire serial bus interface is based on the new IEEE 1394 standard technology that includes industries such as consumer electronics and computer peripheral equipment.

Recognizing the needs for the high speed and performance I/O connection system, Amphenol has developed such interconnection systems capable to operate data transmission rates up to 400 Mbps. This affordable, non-proprietary interconnect system for all digital devices, is a truly universal connection.

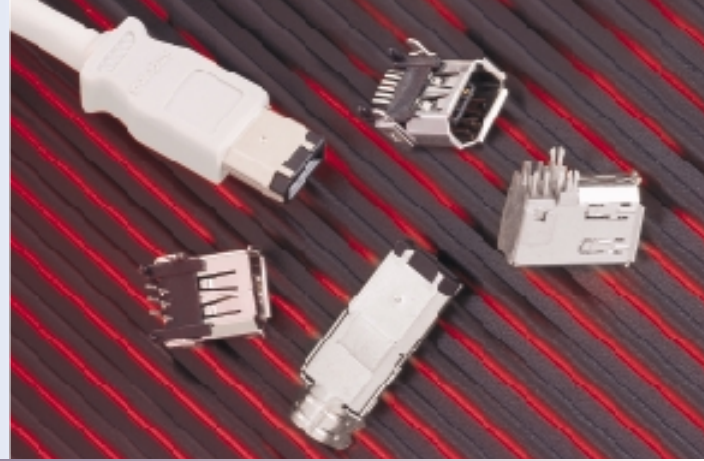

APPLICATIONS

- Computer peripherals such as scanners, laser printers, notebooks and storage units
- Digital video equipment such as cameras and recorders
- TV related devices like HDTV, set-top boxes, VCR and DVD
- Network communications equipment such as telecom switches and modems

FEATURES

- High temperature plastic material
- Compact, fully metal shielded interconnect system to support ESD protection
- Rated for minimum 1500 mating/unmating cycles
- Hot pluggable for "plug & play" applications
- First mate, last break for 2 power/ground contacts
- Up to 400 Mbps data transmission rates
- Rugged gold plated ribbon style contacts

PRODUCT SPECIFICATIONS

Contact: Phosphor bronze (plug) and Brass (receptacle) plated in various finishes in mating area; 120 μ m tin-lead on termination area with contact under plated 50 μ m nickel.

Conductor Resistance: 0.3 ohms max. at 1 amp. DC

SURFACE MOUNT, R/A FLAT

Part Number U33-AC1-110
U33-AC1-111 (TAPE & REEL)

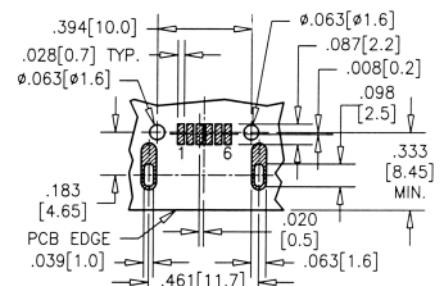
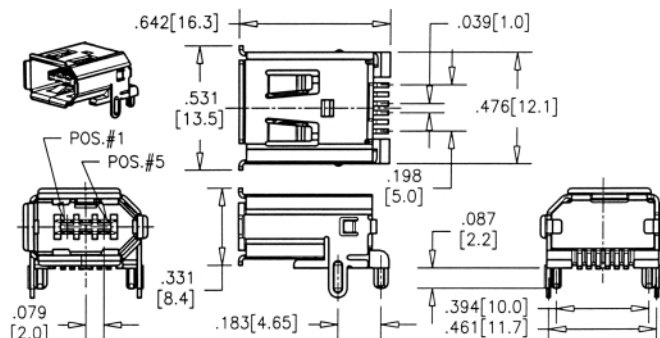

RECOMMENDED PCB LAYOUT

Amphenol®

THROUGH HOLE, R/A UPRIGHT

Part Number U33-AA1-110

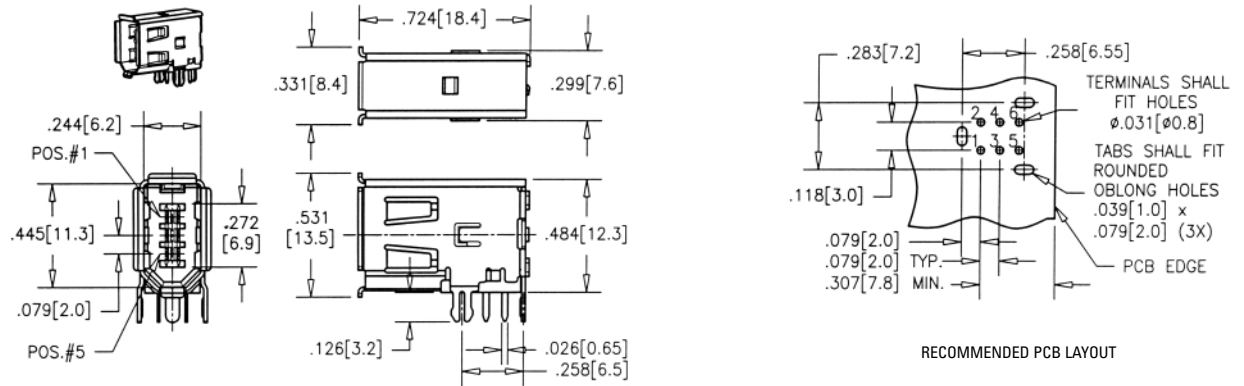

THROUGH HOLE, R/A FLAT

Part Number U33-AG1-11A

