



## Searches

[Part Information](#) | [Specifications](#) | [Line Drawings](#) | [Assembly Instructions](#) | [Panel Cutout](#)

### Quick Search

Global Part Search **NEW!**

Global Search

### Company Information

About Tuchel

Amphenol Corporate

Our Commitment

Terms & Conditions

Environmental Information

### Online Catalogs

Automotive Interconnect

Industrial Connectors

Search by Family

Search by Part

Process Info Request

Download Catalog

Smart Card Connectors

### Contact Information

Find a Sales Location

Distributors

Technical Support

Contact Us

Amphenol Corporation



### Part Information:



**Part Number:** T 3263 400

**Description:** Female receptable, screwlocking, rear mounting, straight dip solder termination, silver plating, ring nut, 10.5mm, 3 DIN

**Family:** C091A

Click below to add part to your request list.  
When you have finished browsing, click "Process Info Request" button.



**Purchase this part**

## Specifications

General	Standard	Characteristics
Number of contacts		3
View on termination side of contact insert		
Contact arrangement according to DIN		41 524
Contact arrangement according to IEC		130-9
Electrical		
Rated voltage	IEC 60664-1	300 V
Rated impulse withstand voltage	IEC 60664-1	1500 V

Pollution degree	IEC 60664-1	1
Installation category	IEC 60664-1	I
Insulation group	IEC 60664-1	3
Test voltage	IEC 60664-1	908 V
Current rating	IEC 60512-3 Test 5 b	5 A / +40°C/ _104°F
Insulation resistance	IEC 60512-2 Test 3 a	>10 <sup>12</sup> Ω
Contact resistance	IEC 60512-2 Test 2 a	<5 m Ω
<b>Climatical</b>		
Climatic category	IEC 60068-1	40 / 85 / 56
Temperature range	IEC 60068-1	-40°C ... +85°C/-40°F ... +185°F
<b>Mechanical</b>		
IP-degree	IEC 60529	IP 40
Insertion and withdrawal forces	IEC 60512-7 Test 13 b	25 N 90.oz
Mechanical operation	IEC 60512-5 Test 9 a	Silver ≥ 500 mating cycles Gold ≥ 1000 mating cycles
<b>Materials</b>		
Housing		die cast, nickel plated
Dielectric		thermoplastic
Contact plating		silver plated, gold plated
<b>Other Characteristics</b>		
Termination technique		solder, crimp
Wire gauge		solder ≤ 0.5mm <sup>2</sup> (20-26 AWG) crimp 0.14-1.0mm <sup>2</sup> (26-18 AWG)
Flammability		UL 94 VO
Locking system	IEC 103-9	metal screw coupling



**Line Drawings**

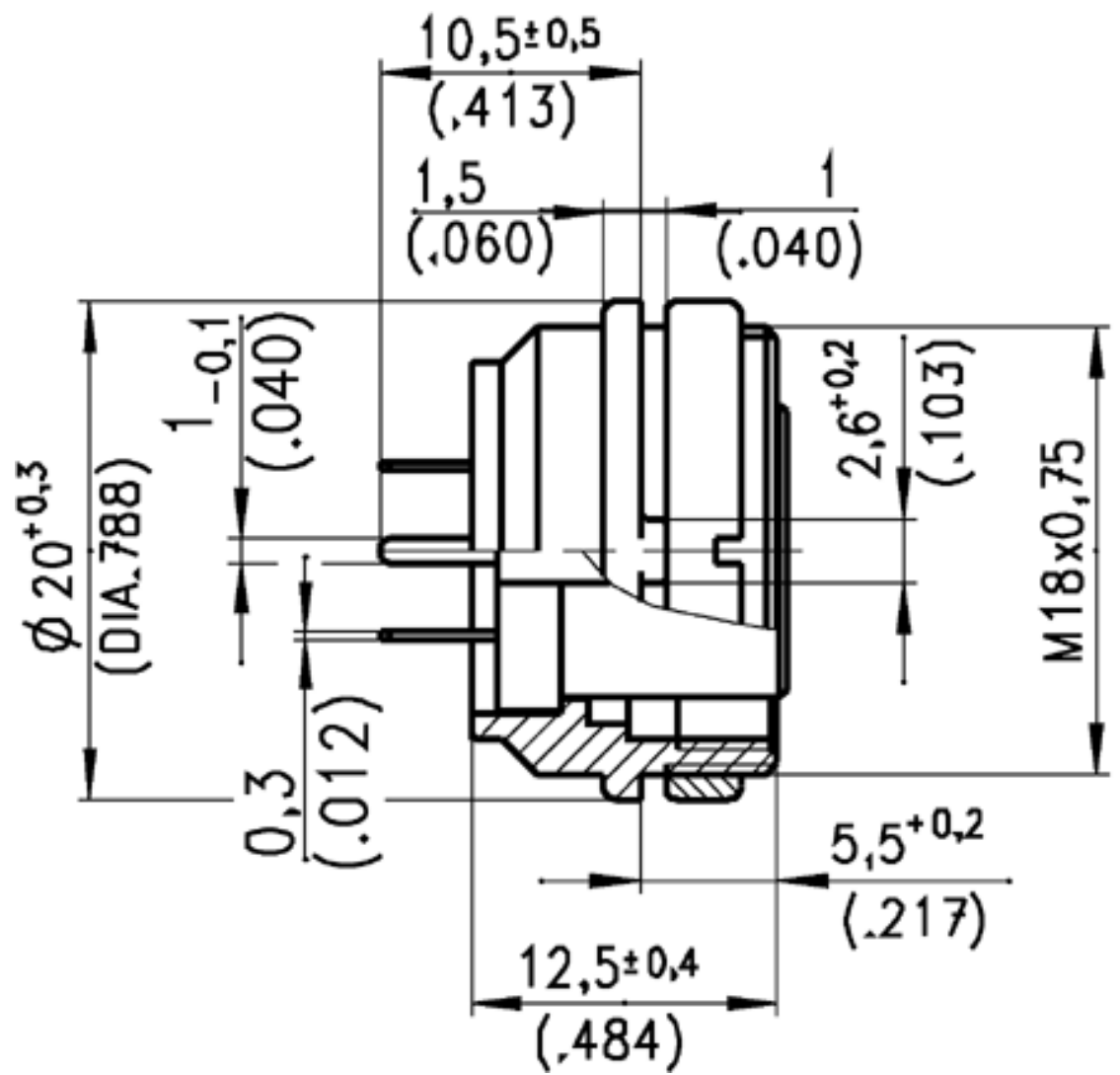

**TOP** Panel Cutout

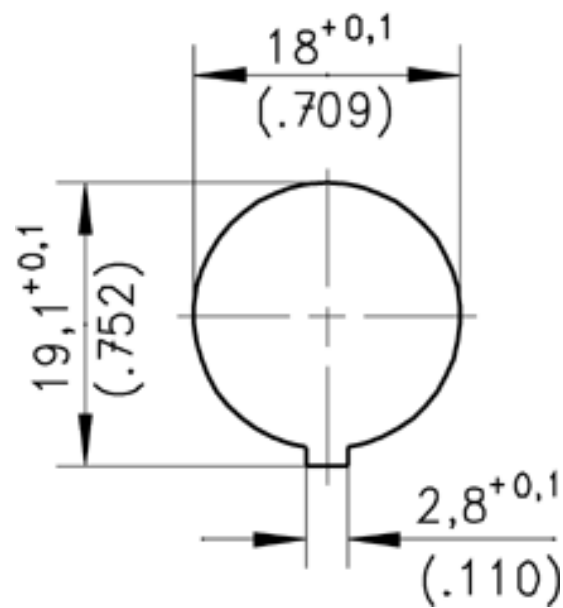

**TOP** Assembly Instructions

