

REV.	DATE	DESCRIPTION
A	03/12/03	UPDATE DRAWING FORMAT

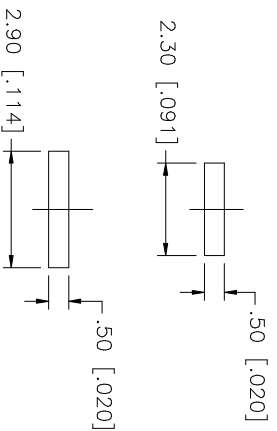
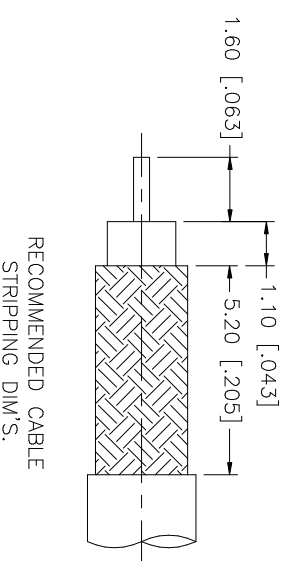
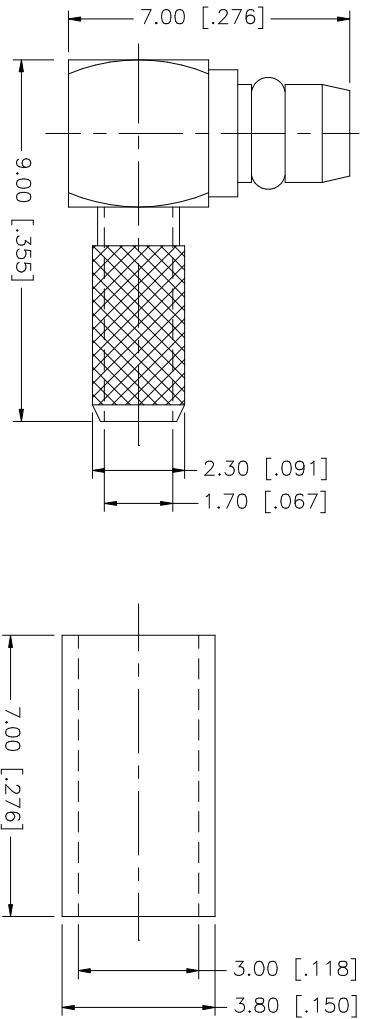

NOTE:

1. CRIMPED FERRULE
HEX CRIMP SIZE .128"
2. CONTACT PIN TO SOLDER

DESCRIPTION	MATERIAL	FINISH	QTY	DO NOT SCALE DRAWING	APPROVALS	DATE	PART DESCRIPTION
8					DRAWN	03/12/03	Amphenol Connex MMCX R/A CRIMP PLUG (FOR RG-174/U, 188A/U, 316/U)
7					CHECKED		
6	FERRULE	COPPER	1		ISSUED		
5	COVER	BRASS	1		SHEET	1 OF 1	
4	INSULATOR	TEFLON	1				
3	CONTACT PIN	BRASS	1				
2	INSULATOR	TEFLON	1				
1	BODY	BRASS	1				

UNLESS OTHERWISE SPECIFIED DIMENSIONS ARE IN MILLIMETERS; DIMENSIONS IN [] ARE IN INCHES AND FOR CUSTOMER REFERENCE ONLY.
 UNLESS OTHERWISE SPECIFIED TOLERANCES FOR MILLIMETERS ARE:
 0.5 - 8mm ± 0.20mm
 8 - 30mm ± 0.40mm
 30 - 120mm ± 0.50mm
 UNLESS OTHERWISE SPECIFIED TOLERANCES FOR INCHES ARE:
 .020 - .315 = ± 0.0007"
 .315 - 1.180 = ± 0.015"
 1.180 - 4.724 = ± 0.020"

APPROVALS	DATE
G.R.S.	03/12/03

CAD FILE	DWG. NO.	REV.	SIZE	SCALE
C:/262/262103.DWG	262103.DWG	A	A	NA