

REV.	DATE	DESCRIPTION
A	01/29/00	UPDATE FERRULE
B	01/02/01	MODIFY BARREL / ADD HEAT SHRINK
C	04/31/03	UPDATE DRAWING FORMAT

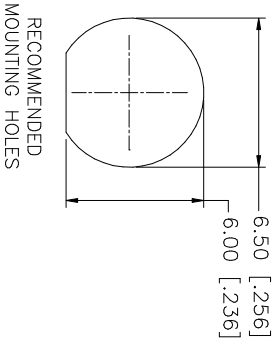
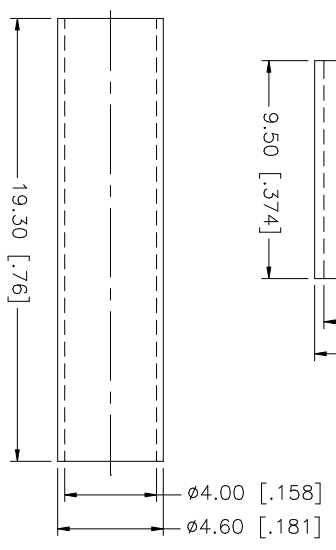
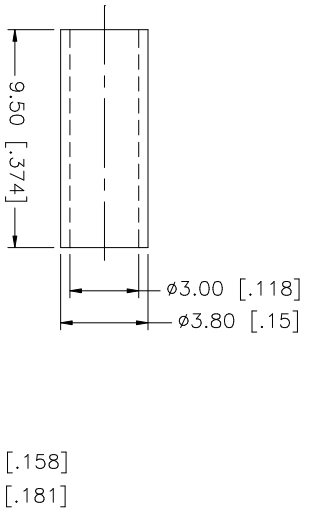
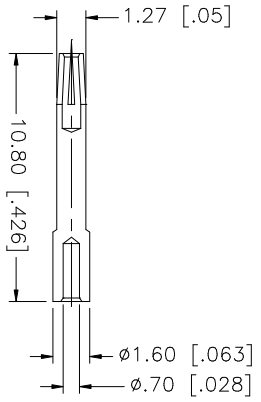
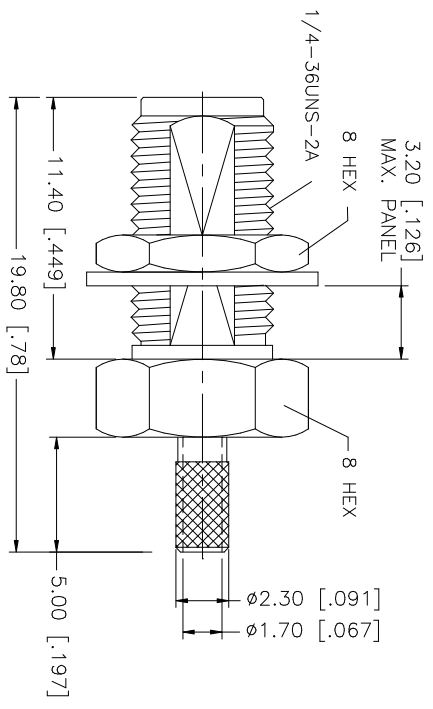
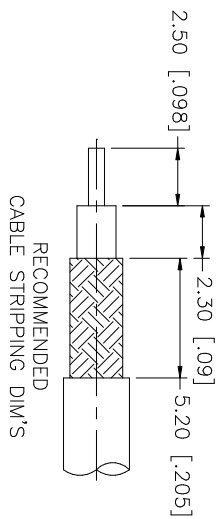

- CRIMP NOTES:
1. CRIMPED FERRULE
HEX CRIMP SIZE .128"
 2. CONTACT PIN TO SOLDER
 3. MAX. PANEL THICKNESS = 3.2mm

QTY	FINISH	MATERIAL	DESCRIPTION
1	GOLD	COPPER	HEAT SHRINK TUBING
1	GOLD	BRASS	FERRULE
1	GOLD	BRASS	LOCK WASHER
1	GOLD	BRASS	HEX NUT
1	GOLD	BER. COPPER	CONTACT PIN
1	NATURAL	TEFLON	INSULATOR
1	GOLD	BRASS	BODY

UNLESS OTHERWISE SPECIFIED DIMENSIONS ARE IN MILLIMETERS DIMENSIONS IN [] ARE IN INCHES AND FOR CUSTOMER REFERENCE ONLY.	UNLESS OTHERWISE SPECIFIED TOLERANCES FOR MILLIMETERS ARE:	UNLESS OTHERWISE SPECIFIED TOLERANCES FOR INCHES ARE:
	0.5 - 8mm ± 0.20mm	.020 - .315 = ± 0.007"
	8 - 30mm ± 0.40mm	.315 - 1.180 = ± 0.015"
	30 - 120mm ± 0.50mm	1.180 - 4.724 = ± 0.020"

APPROVALS	DATE	PART DESCRIPTION
DRAWN G.R.S.	04/31/03	SMA BULKHEAD CRIMP JACK (FOR RG-174/U, 188A/U, 316/U CABLE)
CHECKED		
ISSUED		
SHEET 1 OF 1		PART NO. 132119

CAD FILE	DWG. NO.	REV.	SIZE	SCALE
C:/132/132119.DWG	132119.DWG	C	A	NA

Amphenol Connex