



Solving your relay requirements since 1922

CR Series TDR



- ... Solid state analog circuitry
- ... Triggered delay on release timing mode
- ... Compact size
- ... Relay output with SPST or SPDT contacts
- ... Timing selection: Fixed or knob adjustable
- ... Numerous models timing from 1 sec. to 600 secs.
- ... UL File # E96739 (M)
- ... CSA File #LR62586

Timing Mode: Input voltage must be applied continuously to operate the internal relay. Relay contacts transfer when the trigger input terminal is activated. The timing cycle begins when the trigger input terminal is deactivated. When the timing cycle is completed the relay will de-energize. The timing cycle may be reset to zero during the timing cycle by reactivating the trigger input terminal.

Timing Diagram:

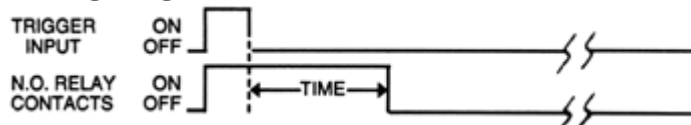

Contact Information:

Arrangement:

- 1 form A (SPST Normally open) - Diagram A
- 1 form B (SPST Normally closed) - Diagram A
- 1 form C (SPDT) - Diagram B

Contact Rating (Resistive)	Max. switching power	30W, 50VA
	Max. switching voltage	60V DC, 125V AC
	Max. switching current	1A DC, AC
	Max. carrying current	0.5A AC; 1A 30V DC
UL/CSA rating 0.5A AC; 1A 30V, DC		



Solving your relay requirements since 1922

Expected Life @ 25°C:
100,000 operations minimum at rated loads

Environmental Information:

Temperature Range:
Operating and storage: -25°C to +60°C, (-13°F to +140°F)

Mechanical Information:

Termination: .110 inch (standard), .250 inch (optional), or screw terminals (optional)
Enclosure: Black plastic case
Mounting: Single screw or optional 2-screw panel mount
Weight: 0.8 oz (23g) approx.

Outline Dimensions:

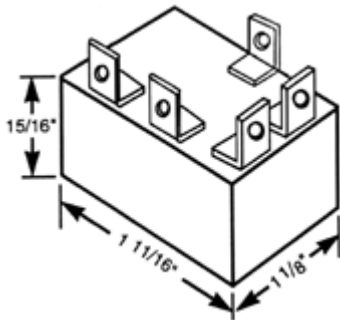

Timing Specifications:

Timing - Fixed: 1 through 600 secs.
Timing Ranges: 1 - 120, 120 - 240, 240 - 480, 480 - 600 secs. **Custom timing is available.**
Timing Adjustment: Knob adjustable potentiometer.
Timing Tolerance: Fixed Units: ±5%; Adjustable Units: -0 to +25% of maximum specified delay time. Minimum specified value or less at low end.
Repeatability: ±5%
Release Time: 60 ms typical, 100 ms maximum

Initial Dielectric Strength:

Between open contacts: 500V RMS, Between contacts & coil: 500V RMS

Input Information:

Voltage:
AC units- 12V, 24V, and 115V; DC units- 12V, 24V, 48V and 110. Other voltages are available
Power Requirement: AC units: 2 VA or less; DC units: 2 Watts or less
Polarity Protection: On DC units - Yes



Solving your relay requirements since 1922

Input Voltages & Limits:

Nominal	Minimum	Maximum
12V AC	10V	14V
24V AC	20V	28V
115V AC	105V	130V
12V DC	11V	14V
24V DC	20V	32V
48V DC	41V	55V
48V DC	95V	125V

Wiring Diagrams:

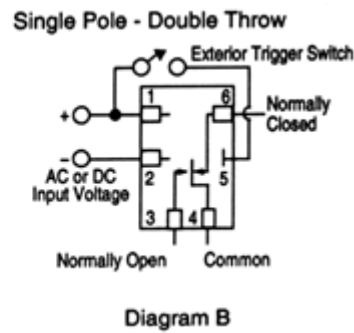
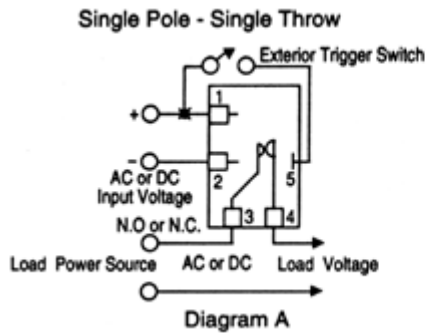

Ordering Information:

Definition of a part number for the Amperite CR Series Time Delay Relay.

Example:

115 A NO R 1 -120 X C

↑ ↑ ↑ ↑ ↑ ↑ ↑ ↑

A B C D E F G H

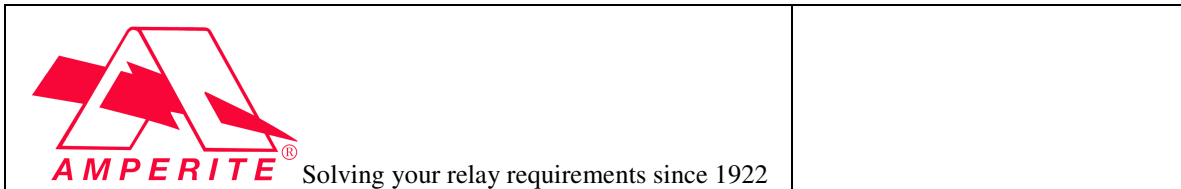

A: Denotes nominal input voltage.

Voltages Available: 12, 24 & 115V AC; 12, 24, 48 & 110V DC. **Custom Voltages are available.**

B: Denotes type of input current required for operation:

A = AC - Alternating Current

D = DC - Direct Current

C: Denotes contact form:

NO = SPST - 1 form A (normally open)

C = SPST - 1 form B (normally closed)

SPDT = 1 form C (single pole, double throw)

D: Denotes trigger reset function of CR Series TDR.

E&F: Denotes range of knob adjustability for timing (in seconds) where:

E = Minimum time delay, F = Maximum time delay for adjustable TDR'S.

Note: 1.) Ranges available: 1 - 120, 120 - 240, 240 - 480 & 480 - 600 secs. Custom Timing is available.

2.) Both values (E & F) can be replaced by a single value for a factory preset time delay in seconds from 1 through 600 seconds

G: Denotes form of termination - blank = .110 male electro-plate solder terminals (standard), X = .250 male quick connect terminals (optional), S = screw terminals (optional).

H: Denotes use of solid state analog circuitry of CR Series.

