



Solving your relay requirements since 1922

SWDC Series Delay-On- Make Timers



- ... CMOS Digital Circuitry
- ... Timing adjustment with 10 position Dip Switch, 1023:1 span
- ... Adjustment resolution 1 part in 1023
- ... DPDT 10 ampere relay contacts
- ... UL File #E96739(M)
- ... CSA File # LR62586

Timing Mode:

Delay on operate timing cycle begins upon application of input power. The relay contacts transfer at the end of the delay period and will remain transferred until input voltage is removed. Reset occurs when input voltage is removed

Timing Diagram:

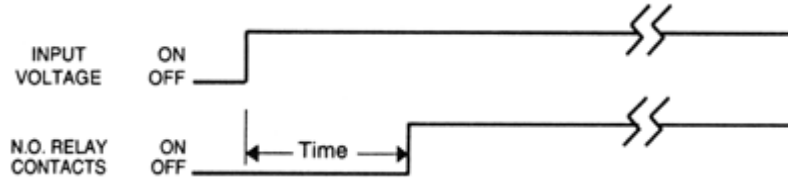

Contact Information:

Arrangement: 2 form C (DPDT) - Diagram C

Contact Material: Silver - Cadmium Oxide

Rating (Resistive):

10A @ 240V AC Resistive

15A @ 30V DC Resistive

15A @ 120V AC Resistive

1/3 HP @ 120V AC

1/2 HP @ 250V AC

Expected Life @ 25 °C:

10 Million operations, Mechanical

100,000 operations minimum at rated loads.

Environmental Information:

Temperature Range:

Storage: -60°C to +105°C (-76°F to +221°F)



Solving your relay requirements since 1922

Operating: -40°C to $+65^{\circ}\text{C}$ (-49°F to $+149^{\circ}\text{F}$)

Mechanical Information:

Termination: 8 pin Octal Style Plug or 11 pin spade terminals (Dia. C&D)

Enclosure: White plastic case. "L" version has a black case.

Weight: 4 oz (114g) approx.

Outline Dimensions:

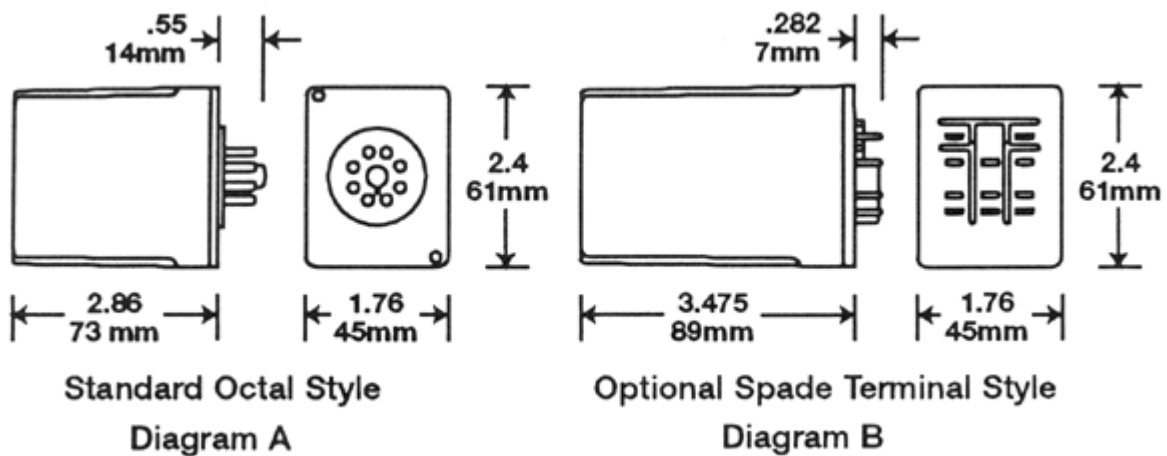

Timing Specifications:

Timing: Three timing ranges, each covering a 1023:1 span, are standard. These are:

A: 0.1 second to 102 seconds

B: 1 second to 1023 seconds (17 minutes)

C: 10 second to 10230 seconds (2.84 hours)

Custom timing ranges are available.

Timing Adjustment:

User operated 10 position DIP switch encoded in binary format.

Adjustment Resolution: Equal to minimum time delay.

Timing Tolerance: $\pm 2\%$

Timing Repeatability: $\pm 1\%$

Timing Cycle Interrupt Transfer: None

Reset: Upon interruption of input power

Initial Dielectric Strength:



Solving your relay requirements since 1922

Between open contacts: 1000V RMS, Between adjacent contacts: 1500V RMS,
Between contacts & coil: 1500V RMS.

Input Information:

Voltage: AC units -12V, 24V and 120V

DC units - 12V, 24V, 48V and 110V

Other voltages are available

Power Requirement:

AC units: 3 VA or less

DC units: 3 Watts or less

Transient Protection: 1 JOULE MOV

Polarity Protection: On DC units - Yes

Input Voltages & Limits:

Nominal	Minimum	Maximum
12V AC	10V	14V
24V AC	20V	28V
120V AC	105V	130V
12V DC	11V	14V
24V DC	20V	32V
48V DC	41V	55V
110V DC	95V	125V

Wiring Diagrams:



Solving your relay requirements since 1922

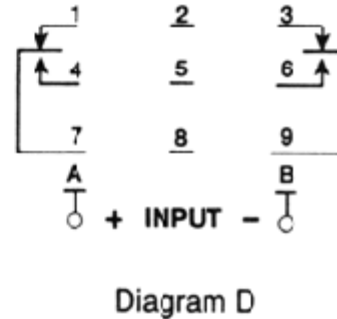
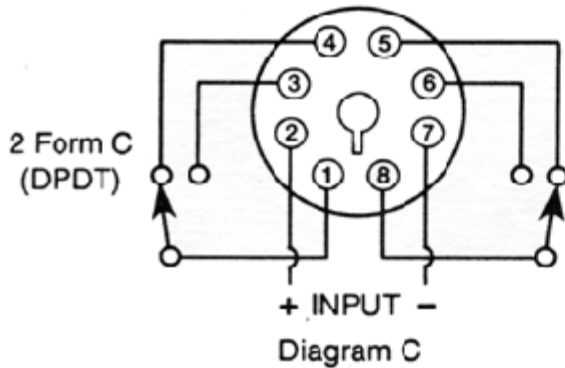

Ordering Information:

Definition of a part number for the Amperite SWDC Series Time Delay Relay:

Example:

120 A 1-1023 S L SWDC
 ↑ ↑ ↑ ↑ ↑ ↑ ↑
 A B C D E F G

A: Denotes nominal input voltage. Standard voltages are 12V, 24V and 120V AC; 12V, 24V, 48V and 110V DC. **Custom Voltages are available.**

B: Denotes type of input current required for operation:

A = AC - Alternate Current

D = DC - Direct Current

C&D: Denotes timing range of adjustability in seconds, minutes, or hours.

E: Denotes unit of time delay: S = seconds; M = minutes; H = hours.

F: Denotes form of termination: Leave blank for standard octal plug-in; Enter "L" if optional spade terminals are required (Diagrams B & D).

G: Denotes use of solid state digital circuitry of SWDC Series.