

20 Amp BLDC Motor/Blower Controller

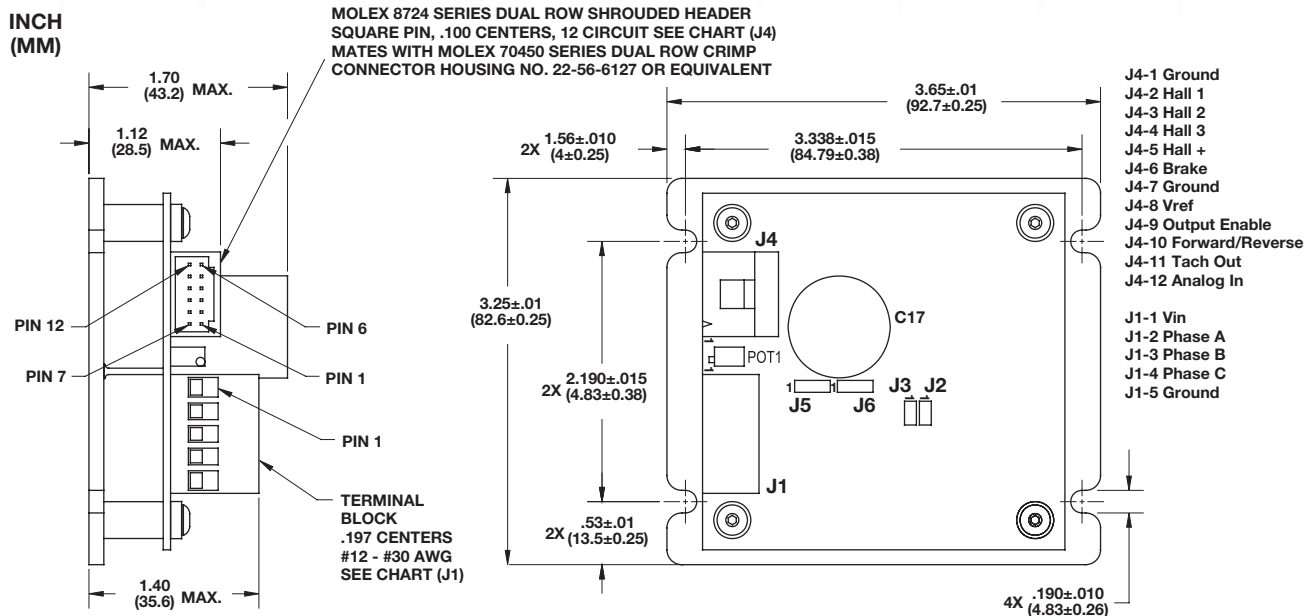

Controller Data	Motor/Blower Controller
	48134*
Maximum Continuous Current	20 A
Input Voltage Range	11-28 VDC
Controller PWM Frequency	25 kHz
Analog Speed Input	0-5 VDC
Electrical Hall Spacing	60° or 120°
Waveform	6-Step Trapezoidal
Current Limit Protection	Yes
Rotation	CW / CCW

*These part numbers are available through AMETEK Technical & Industrial Products distributors.

NOTES:

- **Temperature:** Operating: 0°C to 50°C, Storage Air: -40°C to 85°C.
- **Speed Control:** Electrical speed control is achieved by applying a 0 to 5 VDC signal on J4 Pin 12 with respect to J4 Pin 7. Mechanical speed control is achieved by adjusting the potentiometer when J6 is in position 1 to 2.
- **Current Control:** Trip point is at 20 Amp maximum.

Caution should be taken. Misplacement of jumper setting will destroy the control.

Jumper Settings:

- J2-Motor Sensor Spacing:** 120° electrical spacing with jumper connected (default).
60° electrical spacing with jumper disconnected.
- J3-Rotations:** Clockwise rotation with jumper connected (default).
Counter-clockwise rotation with jumper disconnected.
Do not change while motor is running or damage will occur.
- J5-Input Voltage:** Position 1-2 for 16-52 VDC (default).
Position 2-3 for 11-16 VDC.
- J6-Speed Control:** Position 1-2 for internal speed adjust, via on board potentiometer (default).
Position 2-3 for analog speed input, via 0-5 VDC signal applied to J1 pins 2 and 3.