

**GT3W Series — Dual Time Range Timers**



**Key features of the GT3W series include:**

- Sequential start, sequential interval, on-delay, recycler, and interval ON timing functions
- 2 time settings in one timer
- 8 selectable operation modes on each model
- Mountable in sockets or flush panel
- Power and output status indicating LEDs
- Time ranges up to 300 hours



c-uL Listed  
UL Listed  
File No.E55996



Timers

General Specifications			
<b>Operation System</b>	Solid state CMOS Circuit		
<b>Operation Type</b>	Multi-Mode		
<b>Time Range</b>	1: 0.1sec to 6hours, 3: 0.1sec to 300hours		
<b>Pollution Degree</b>	2 (IE60664-1)		
<b>Over voltage category</b>	III (IE60664-1)		
<b>Rated Operational Voltage</b>	AF20 100-240V AC(50/60Hz)		
	AD24 24V AC(50/60Hz)/24V DC		
	D12 12V DC		
<b>Voltage Tolerance</b>	AF20 85-264V AC(50/60Hz)		
	AD24 20.4-26.4V AC(50/60Hz)/21.6-26.4V DC		
	D12 10.8-13.2V DC		
<b>Disengaging value of Input Voltage</b>	Rated Voltage x10% minimum		
<b>Range of Ambient Operating Temperature</b>	-10 to +50°C (without freezing)		
<b>Range of Ambient Storage and Transport Temperature</b>	-30 to +75°C (without freezing)		
<b>Range of Relative Humidity</b>	35 to 85%RH (without condensation)		
<b>Atmospheric Pressure</b>	80kPa to 110kPa (Operating), 70kPa to 110kPa (Transport)		
<b>Reset Time</b>	60msec maximum		
<b>Repeat Error</b>	±0.2%, ±10msec*		
<b>Voltage Error</b>	±0.2%, ±10msec*		
<b>Temperature Error</b>	±0.6%, ±10msec*		
<b>Setting Error</b>	±10% maximum		
<b>Insulation Resistance</b>	100MΩ minimum (500V DC)		
<b>Dielectric Strength</b>	Between power and output terminals: 2000V AC, 1 minute Between contacts of different poles: 2000V AC, 1 minute Between contacts of the same pole: 750V AC, 1 minute		
<b>Vibration Resistance</b>	10 to 55Hz amplitude 0.75mm <sup>2</sup> hours in each of 3 axes		
<b>Shock Resistance</b>	Operating extremes: 98m/sec <sup>2</sup> (approx. 10G) Damage limits: 490m/sec <sup>2</sup> (approx. 50G) 3 times in each of 3 axes		
<b>Degree of Protection</b>	IP40 (enclosure), IP20 (socket) (IEC60529)		
<b>Power Consumption (Approx.)</b>	AF20	100V AC/60Hz	2.3VA
		200V AC/60Hz	4.6VA
	AD24 (AC/DC)	1.8VA/0.9W	
<b>Mounting Position</b>	Free		
<b>Dimensions</b>	40Hx 36W x 70 mm		
<b>Weight (Approx.)</b>	72g		

Contact Ratings		
<b>Allowable Contact Power</b>	960VA/120W	
<b>Allowable Voltage</b>	250V AC/150V DC	
<b>Allowable Current</b>	5A	
<b>Maximum permissible operating frequency</b>	1800 cycles per hour	
<b>Rated Load</b>	1/8HP, 240V AC	
	3A, 240V AC (Resistive)	
	5A, 120V AC/30V DC (Resistive)	
<b>Conditional Short Circuit</b>	Fuse 5A, 250V	
<b>Life</b>	Electrical	100,000 op. minimum (Resistive)
	Mechanical	20,000,000 op. minimum

**GT3W Table of Contents**

- Specifications — G-44
- Part Number List — G-45
- Timing Diagrams / Schematics — G-46
- Instructions: Setting Timer — G-47
- GT3 Accessories — G-48
- GT3 Instructions — G-50
- GT3 Dimensions — G-52
- Timing Diagrams Overview — G-4



\*\* For the value of the error against a preset time, whichever the largest.

## Part Number List

### Part Numbers

Mode of Operation	Output	Contact	Time Range*	Rated Voltage	Pin Configuration	New Part Numbers
A: Sequential Start B: On-delay with course & fine C: Recycler & instantaneous D: Recycler outputs (OFF Start) E: Recycler outputs (ON Start) F: Interval ON G: Interval ON Delay H: Sequential Interval	3A, 240V AC	Delayed SPDT + Delayed SPDT	1: 0.1sec - 6 hours  *(See Time Range Settings for details.)	100 to 240V AC (50/60Hz)	8 pin	GT3W-A11AF20N
					11 pin	GT3W-A11EAF20N
				24V AC/DC	8 pin	GT3W-A11AD24N
					11 pin	GT3W-A11EAD24N
				12V DC	8 pin	GT3W-A11D12N
	11 pin	GT3W-A11ED12N				
	100 to 240V AC (50/60Hz)	8 pin	GT3W-A33AF20N			
			24V AC/DC	GT3W-A33AD24N		



1. For schematics, see page G-46.
2. For socket and accessory part number information, see page G-48.
3. 8- and 11-pin models differ only in the number of pins (extra pins are not used).
4. For the timing diagram overview, see page G-4.
5. \*For details on setting time ranges, see the instructions on page G-47.

## Time Range Table

Time Range Code: 1			Time Range Code: 3		
Time Range Selector	Scale	Time Range	Time Range Selector	Scale	Time Range
1S	0-1	0.1 sec - 1 sec	1S	0 - 3	0.1 sec - 3 sec
10S		0.3 sec - 10 sec	1M		3 sec - 3 min
10M		15 sec - 10 min	1H		3 min - 3 hours
1S	0 - 6	0.1 sec - 6 sec	1S	0 - 30	0.6 sec - 30 sec
10S		1 sec - 60 sec	1M		36 sec - 30 min
1M		6 sec - 6 min	1H		36min - 30 hours
10M		1 min - 60 min	10H		6 hours - 300 hours
1H		6 min - 6 hours			

Timing Diagrams/Schematics

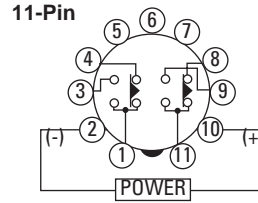
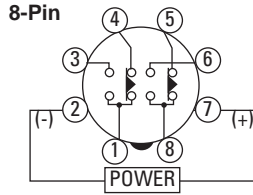

MODE	Operation chart			MODE	Operation chart		
A : Sequential Start	Item	Terminal No.	Operation	E : Recycler outputs (ON Start)	Item	Terminal No.	Operation
	Power	2-7(8p) 2-10(11p)	[Timing diagram showing power pulse]		Power	2-7(8p) 2-10(11p)	[Timing diagram showing power pulse]
B : On-delay with course and fine	Delayed Contact Ry1	1-4(8p) 1-4(11p) (NC) 1-3(8p) 1-3(11p) (NO)	[Timing diagram showing Ry1 output]	F : Interval ON	Delayed Contact Ry1	1-4(8p) 1-4(11p) (NC) 1-3(8p) 1-3(11p) (NO)	[Timing diagram showing Ry1 output]
	Delayed Contact Ry2	5-8(8p) 8-11(11p) (NC) 6-8(8p) 9-11(11p) (NO)	[Timing diagram showing Ry2 output]		Delayed Contact Ry2	5-8(8p) 8-11(11p) (NC) 6-8(8p) 9-11(11p) (NO)	[Timing diagram showing Ry2 output]
C : Recycler and instantaneous	Indicator	OUT1 OUT2	[Timing diagram showing indicator outputs]	G : Interval ON Delay	Indicator	OUT1 OUT2	[Timing diagram showing indicator outputs]
	Set Time		T1 T2		Set Time		T1 T2
D : Recycler outputs (OFF Start)	Delayed Contact Ry1	1-4(8p) 1-4(11p) (NC) 1-3(8p) 1-3(11p) (NO)	[Timing diagram showing Ry1 output]	H : Sequential Interval	Delayed Contact Ry1	1-4(8p) 1-4(11p) (NC) 1-3(8p) 1-3(11p) (NO)	[Timing diagram showing Ry1 output]
	Delayed Contact Ry2	5-8(8p) 8-11(11p) (NC) 6-8(8p) 9-11(11p) (NO)	[Timing diagram showing Ry2 output]		Delayed Contact Ry2	5-8(8p) 8-11(11p) (NC) 6-8(8p) 9-11(11p) (NO)	[Timing diagram showing Ry2 output]
	Indicator	OUT1 OUT2	[Timing diagram showing indicator outputs]	Indicator	OUT1 OUT2	[Timing diagram showing indicator outputs]	
	Set Time		T1 T2 T1 T2	Set Time		T1 T2	

Timers

## Instructions: Setting GT3W Timer

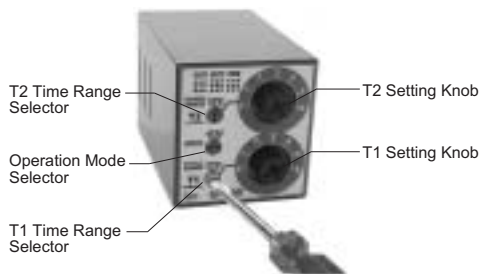

1. The switches should be securely turned using a flat screwdriver 4mm wide (maximum). Note that incorrect setting may cause malfunction. The switches, which do not turn infinitely, should not be turned beyond their limits.
2. Since changing the setting during timer operation may cause malfunction, turn power off before changing.

## Safety Precautions

Special expertise is required to use Electronic Timers.

- All Electronic Timer modules are manufactured under IDEC's rigorous quality control system, but users must add a backup or fail safe provision to the control system when using the Electronic Timer in applications where heavy damage or personal injury may occur should the Electronic Timer fail.
- Install the Electronic Timer according to instructions described in this catalog.
- Make sure that the operating conditions are as described in the specifications. If you are uncertain about the specifications, contact IDEC in advance.
- In these directions, safety precautions are categorized in order of importance to Warning and Caution.

### Warning

Warning notices are used to emphasize that improper operation may cause severe personal injury or death.

- Turn power off to the Electronic timer before starting installation, removal, Wiring, maintenance, and inspection on the Electronic Timer.
- Failure to turn power off may cause electrical shocks or fire hazard.
- Emergency stop and interlocking circuits must be configured outside the Electronic timer. If such a circuit is configured inside the Electronic Timer, failure of the Electronic timer may cause malfunction of the control system, or an accident.

### Caution

Caution notices are used where inattention might cause personal injury or damage to equipment.

- The Electronic Timer is designed for installation in equipment. Do not install the Electronic Timer outside equipment.
- Install the Electronic Timer in environments described in the specifications. If the Electronic Timer is used in places where it will be subjected to high-temperature, high-humidity, condensation, corrosive gases, excessive vibrations, or excessive shocks, then electrical shocks, fire hazard, or malfunction could result.
- Use an IEC60127-approved fuse and circuit breaker on the power and output line outside the Electronic Timer.
- Do not disassemble, repair, or modify the Electronic Timer.
- When disposing of the Electronic Timer, do so as industrial waste.

**Accessories: GT3 Series**

**DIN Rail Mounting Accessories**

**Part Numbers: DIN Rail/Surface Mount Sockets and Hold-Down Springs**

DIN Rail Mount Socket				Applicable Hold-Down Springs	
Style	Appearance	Use with Timers	Part No.	Appearance	Part No.
8-Pin Screw Terminal (dual tier)		GT3A-1, 2, 3 (8-pin) GT3D-1, 2, 3 (8-pin) GT3F-1, 2 (8-pin) GT3W (8-pin) GT3S	SR2P-05		SFA-203
11-Pin Screw Terminal (dual tier)		GT3A-1, 2, 3 (11-pin) GT3A-4, 5, 6 GT3D-1, 2, 3 (11-pin) GT3D-4, 8 GT3F-1, 2 (11-pin) GT3W (11-pin)	SR3P-05		
8-Pin Fingersafe Socket		GT3A-1, 2, 3 (8-pin) GT3D-1, 2, 3 (8-pin) GT3F-1, 2 (8-pin) GT3W (8-pin) GT3S	SR2P-05C		
11-Pin Fingersafe Socket		GT3A-1, 2, 3 (11-pin) GT3A-4, 5, 6 GT3D-1, 2, 3 (11-pin) GT3D-4, 8 GT3F-1, 2 (11-pin) GT3W (11-pin)	SR3P-05C		SFA-202
8-Pin Screw Terminal		GT3A-1, 2, 3 (8-pin) GT3D-1, 2, 3 (8-pin) GT3F-1, 2 (8-pin) GT3W (8-pin) GT3S	SR2P-06		
11-Pin Screw Terminal		GT3A-1, 2, 3 (11-pin) GT3A-4, 5, 6 GT3D-1, 2, 3 (11-pin) GT3D-4, 8 GT3F-1, 2 (11-pin) GT3W (11-pin)	SR3P-06		
DIN Mounting Rail Length 1000mm		—	BNDN1000		

**Installation of Hold-Down Springs**

**DIN Rail Mount Socket**

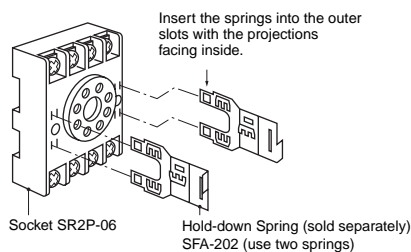

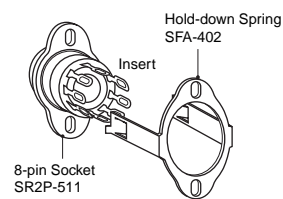

**Panel Mount Socket**



## Panel Mounting Accessories





### Part Numbers: Panel Mount Sockets and Hold-Down Springs

Panel Mount Socket				Applicable HD Springs	
Style	Appearance	Use with Timers	Part No.	Appearance	Part No.
8-Pin Solder Terminal		GT3A- (8-pin) GT3D- (8-pin) GT3W- (8-pin) GT3F- (8-pin) GT3S	SR2P-51		SFA-402
11-Pin Solder Terminal		GT3A- (11-pin) GT3D- (11-pin) GT3W- (11-pin) GT3F- (11-pin)	SR3P-51		



1. For information on installing the hold-down springs, see page G-48.

### Part Numbers: Flush Panel Mount Adapter and Sockets that use an Adapter

Accessory	Description	Appearance	Use with Timers	Part No.
<b>Panel Mount Adapter</b>	Adaptor for flush panel mounting GT3 timers		All GT3 timers	RTB-G01
<b>Sockets for use with Panel Mount Adapter</b>	8-pin screw terminal	 (Shown: SR6P-M08G for Wiring Socket Adapter)	All 8-pin timers	SR6P-M08G
	11-pin screw terminal		All 11-pin timers	SR6P-M11G
	8-pin solder terminal		All 8-pin timers	SR6P-S08
	11-pin solder terminal		All 11-pin timers	SR6P-S11



2. No hold down springs are available for flush panel mounting.

Dimensions: GT3 Series

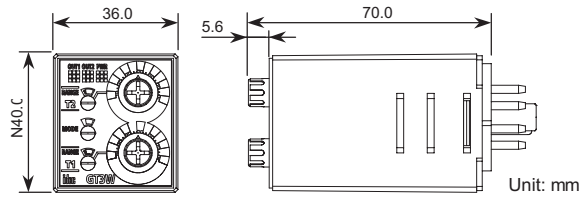

NOTE: GT3W series are UL Listed when used in combination with following IDEC's sockets:  
 GT3W-A11, A33: SR2P-06\* pin type socket.  
 GT3W-A11E, A33: SR3P-05\* pin type socket.  
 (\*-May be followed by A,B,C or U)  
 The socket to be used with these timers are rated:  
 -Conductor Temperature Rating 60°C min.  
 -Use 14AWG max.(2mm<sup>2</sup>max.) Copper conductors only  
 -Terminal Torque 1.0 to 1.3 N-m

Analog GT3 Timer, 8-Pin with SR2P-06

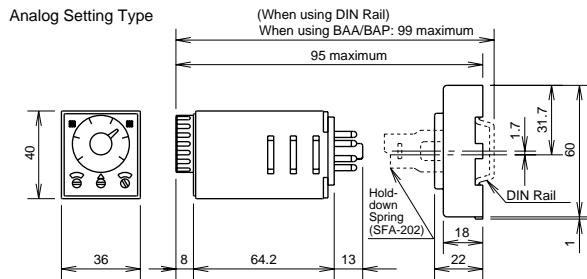

Analog GT3 Timer, 11-Pin with SR3P-06

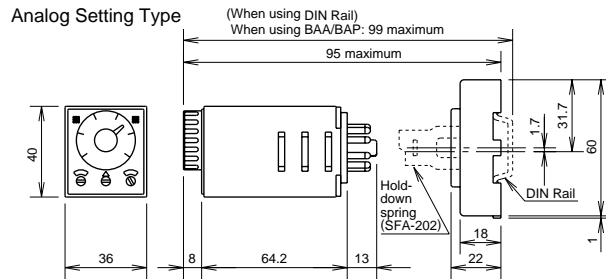

Digital GT3 Timer, 8-Pin with SR2P-06

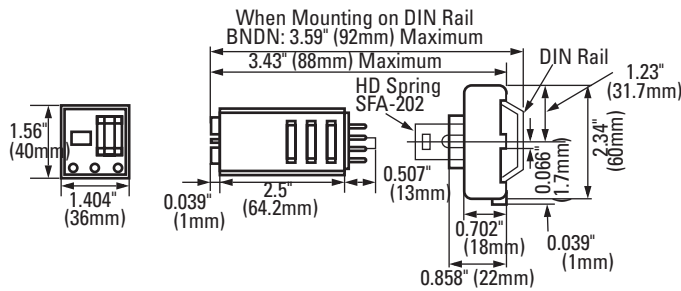

Digital GT3 Timer, 11-Pin with SR3P-06

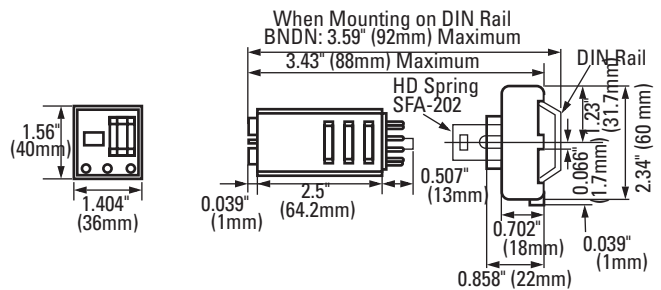

Analog GT3 Timer, 11-Pin with SR3P-05

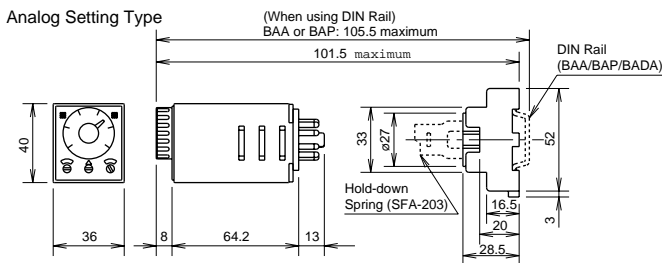

Digital GT3 Timer, 11-Pin with SR3P-05

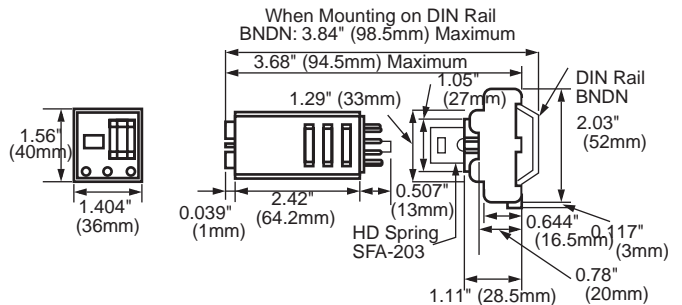

Timers

## Panel Mount Adapter

Analog GT3 Timer, 8-Pin and 11-Pin with SR6P-S08 or SR6P-S11

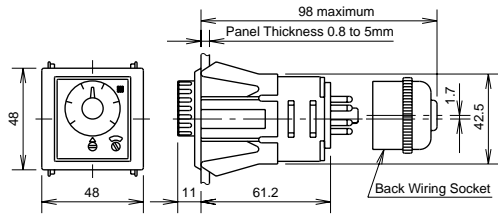

Digital GT3 Timer, 8-Pin and 11-Pin with SR6P-S08 or SR6P-S11

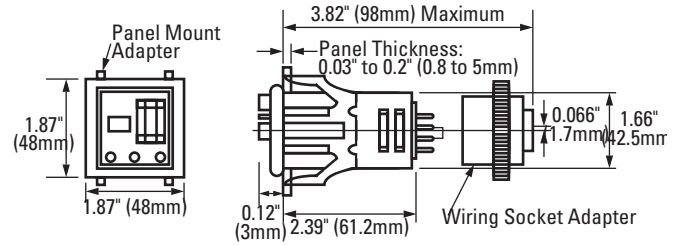

## Mounting Hole Layout

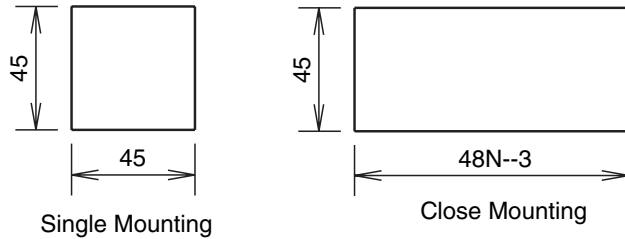

Analog and Digital GT3 Timer, 8-Pin with SR6P-M08G

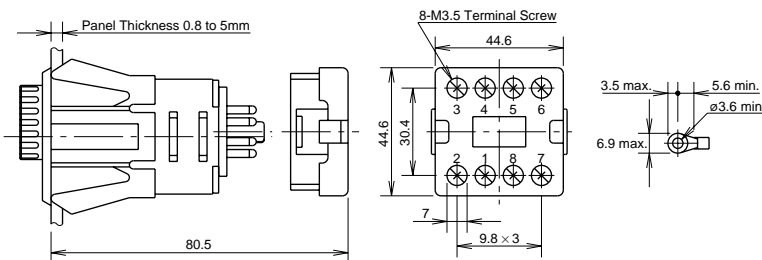

Analog and Digital GT3 Timer, 11-Pin with SR6P-M11G

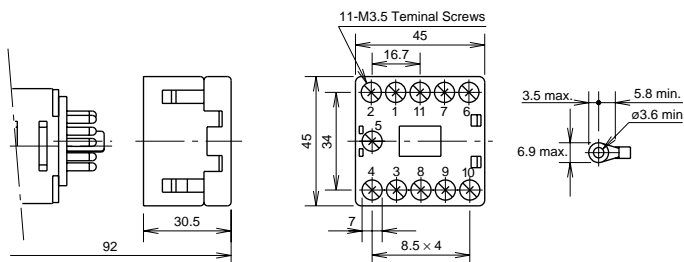



## General Instructions for All Timer Series

### Load Current

With inductive, capacitive, and incandescent lamp loads, inrush current more than 10 times the rated current may cause welded contacts and other undesired effects. The inrush current and steady-state current must be taken into consideration when specifying a timer.

### Contact Protection

Switching an inductive load generates a counter-electromotive force (back EMF) in the coil. The back EMF will cause arcing, which may shorten the contact life and cause imperfect contact. Application of a protection circuit is recommended to safeguard the contacts.

### Temperature and Humidity

Use the timer within the operating temperature and operating humidity ranges and prevent freezing or condensation. After the timer has been stored below its operating temperature, leave the timer at room temperature for a sufficient period of time to allow it to return to operating temperatures before use.

### Environment

Avoid contact between the timer and sulfurous or ammonia gases, organic solvents (alcohol, benzene, thinner, etc.), strong alkaline substances, or strong acids. Do not use the timer in an environment where such substances are prevalent. Do not allow water to run or splash on the timer.

### Vibration and Shock

Excessive vibration or shocks can cause the output contacts to bounce, the timer should be used only within the operating extremes for vibration and shock resistance. In applications with significant vibration or shock, use of hold down springs or clips is recommended to secure a timer to its socket.

### Time Setting

The time range is calibrated at its maximum time scale; so it is desirable to use the timer at a setting as close to its maximum time scale as possible. For a more accurate time delay, adjust the control knob by measuring the operating time with a watch before application.

### Input Contacts

Use mechanical contact switch or relay to supply power to the timer. When driving the timer with a solid-state output device (such as a two-wire proximity switch, photoelectric switch, or solid-state relay), malfunction may be caused by leakage current from the solid-state device. Since AC types comprise a capacitive load, the SSR dielectric strength should be two or more times the power voltage when switching the timer power using an SSR.

Generally, it is desirable to use mechanical contacts whenever possible to apply power to a timer or its signal inputs. When using solid state devices, be cautious of inrushes and back-EMF that may exceed the ratings on such devices. Some timers are specially designed so that signal inputs switch at a lower voltage than is used to power the timer (models designated as "B" type).

## Timing Accuracy Formulas

Timing accuracies are calculated from the following formulas:

$$\text{Repeat Error} = \pm \frac{1}{2} \times \frac{\text{Maximum Measured Value} - \text{Minimum Measured Value}}{\text{Maximum Scale Value}} \times 100\%$$

$$\text{Voltage Error} = \pm \frac{T_v - T_r}{T_r} \times 100\%$$

$T_v$ : Average of measured values at voltage V  
 $T_r$ : Average of measured values at the rated voltage

$$\text{Temperature Error} = \pm \frac{T_t - T_{20}}{T_{20}} \times 100\%$$

$T_t$ : Average of measured values at °C  
 $T_{20}$ : Average of measured values at 20°C

$$\text{Setting Error} = \pm \frac{\text{Average of Measured Values} - \text{Set Value}}{\text{Maximum Scale Value}} \times 100\%$$